

Medical Isolated Power Panels

Catalog
4800CT1201R09/15
2015
Class 4800



CONTENTS

Description	Page
Overview	2
Components	4
Standard Panels	7
Duplex Panels	11
Dual Voltage Panels	15
Controlled Panels	20
X-Ray/Power Receptacle Modules	25
Power Modules	27
Master Grounding Station Modules	27
Hospital-Grade Ground Cords	28
Iso-Gard™ IGT Dual Clock/Timer Kit	28
IG2000 Series Remote Indicators	29
Transformers	32
Backbox/Front Trim Combinations	35
Replacement Parts	35
Main Disconnect Circuit Breaker Size	36
Installing and Connecting Isolated Power Systems	37

Medical Isolated Power Panels Overview

Controlled Isolated Power Panel



Isolated Power Systems

Isolated power systems offer an invaluable advantage in medical settings—early detection allows critical systems to remain online when hazardous current is present. The system gives a visual indication of the level of current in milliamperes (mA). If the system reaches a threshold of 3.7 mA, the visual and audible alarm indicates the presence of an excessive amperage level instead of disconnecting the circuit. These systems provide isolated power in operating rooms and other critical areas.

An isolation transformer serves a single operating room, except when supplying equipment requiring 150 V or higher (example: receptacles for laser/X-ray machines).

A line isolation monitor (LIM) indicates possible leakage or fault currents from all isolated conductors to ground.

- A green LED remains lit when the system is adequately isolated from ground.
- Under normal voltage conditions, a red LED lamp and audible warning signal activate when a fault hazard current (fault leakage current only) reaches a threshold value of 3.7 mA, or when the total hazard current reaches a threshold value of 5.0 mA.
- A digital display indicates the total hazard current of the system.

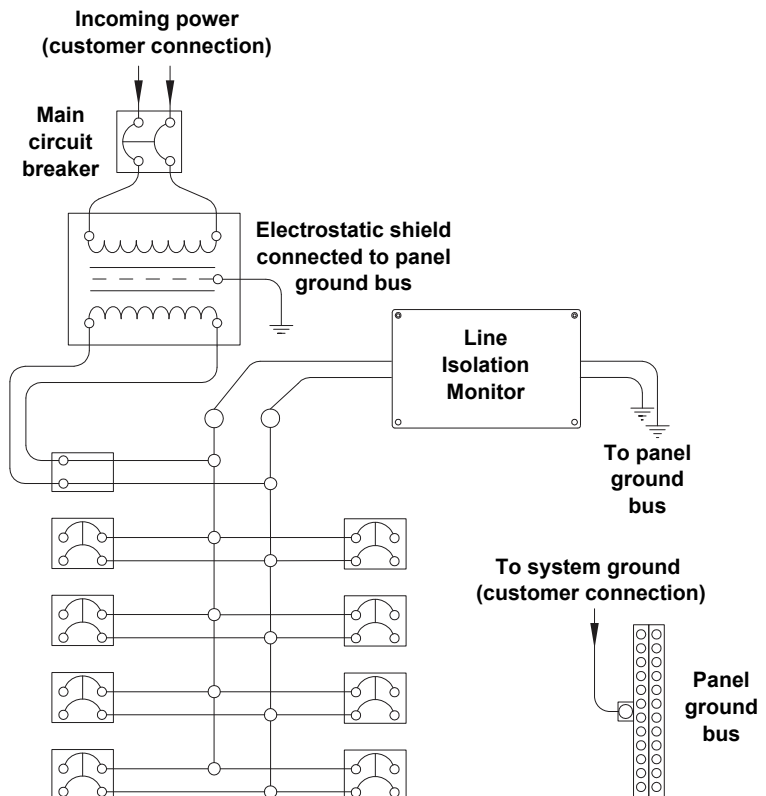

For questions, further assistance, or additional equipment or custom requirements, please contact your local Schneider Electric representative.

Panel Types

Standard Panels

Standard panels offer the most compact solution for a single isolated power system.

- Available in four options: 3, 5, 7.5, or 10 kVA
- Up to 16 circuits

Duplex Panels

Duplex panels offer two isolated power systems in a single panel. The systems are separated from each other by a barrier. For example, they can be used to enclose a standard and an emergency isolated power system in a single back box with common trim.

- Each panel supplies both 120 V and 208 V
 - 120 V system has up to 16 circuits
 - 208 V options include:
 - 5 kVA system with a 30 A secondary main in a 16-circuit panelboard
 - 7.5 kVA system with a 40 A secondary main in a 16-circuit panelboard
 - 10 kVA system with a 50 A secondary main in a 16-circuit panelboard
- Duplex panels are used when multiple panels are required in an operating room and/or more than 16 circuits are required

Dual Voltage Panels

Dual voltage panels supply both 120 V and 208 V isolated power to an operating room.

- Back box requires a 14-inch-deep wall
- Each panel supplies up to 16, 120 V circuits, plus
 - One 30 A, 208 V circuit for equipment such as a laser receptacle
 - One 50 A, 208 V circuit for equipment such as an X-ray receptacle

Controlled Panels

Controlled panels are designed to provide 208 V of isolated power to multiple areas from one central location. They can be used to add 208 V to existing rooms.

Medical Isolated Power Panels Components

Isolated Power Panel Components

(Feeding 120, 208, or 240 V power circuits)

Isolation Transformer

Hospital-grade isolation transformers from Schneider Electric provide isolation between system voltage and load requirements.



- Single-phase
- kVA range: 3, 5, 7.5, 10, 15, 25 kVA
- Primary voltages: 120, 208, 240, 277, or 480 V
- Secondary voltages: 120, 208, or 240 V
- Class 180 insulation
- Electrostatic shield
- Maximum sound level of 35dB
- Low leakage
- Compliance with UL 1047 (tables 30.1 and 30.2) and CSA Z32.2

NQ Panelboard Interiors

Schneider Electric has designed a single-phase, NQ panelboard interior for use in isolated power panels.

- Accepts plug-on or bolt-on branch circuit breakers
- 100 A interiors

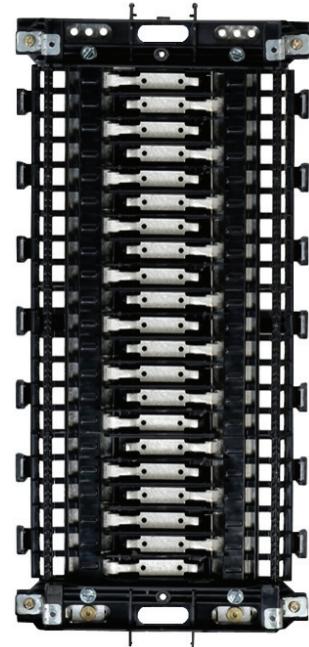

QO™ Branch Circuit Breakers

- 10k AIR
- QO (plug on) or QOB™ (bolt on)
- 20 A; 2-pole (120 V)
- 20, 30, 50 or 60 A; 2-pole (208 or 240 V)

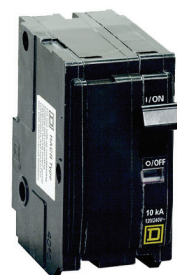

QO



QOB

Primary Circuit Breakers



PowerPact H-frame

- QO circuit breakers for 120, 208, and 240 V systems
- PowerPact™ H-frame circuit breakers for 277 and 480 V systems
- 2-pole; size is based on transformer kVA and chosen primary voltage

Iso-Gard™ Series 6 Line Isolation Monitor (LIM)

- Automatic operating voltage selection reduces repairs and technical calls and increases customer satisfaction.
- Automatic self test with data logging reduces time required to perform periodic testing.
- Communications bus provides centralized monitoring of LIM installations to improve predictive maintenance.
- Built-in ground fault location system reduces the time required to locate detected fault(s).
- Plain text menu interface makes setting easier and alarms clearer.
- Electrical system measurements help determine the root cause of a detected fault.



Feature	Value	Feature	Value
Measuring range Z_{ISO}	10–999 kW	Load current monitoring	Yes
Measuring range R_{ISO}	20–999 kW	Transformer temperature monitor	Yes
Measuring range C_{LEAK}	10–200 nF	Automatic operating voltage selection	Yes
Trip time (0 - > 5 mA)	3.5 sec.	Automatic self test	Yes (selectable time)
Trip tolerance (THC)	4.5–5 mA	Line to line voltage measurement	70–276 V
Detected fault location	Yes	Line to ground voltage measurement	> 0–276 V
Event memory with time stamp	Yes	Detected faulty line indication	Yes
Communication bus compatibility	Full	Select different measuring frequencies	Yes
Device settings	Plain text	Split core measuring current	Yes

Medical Isolated Power Panels Components

The following drawing shows some of the components typically installed in a power panel (in this case, a standard isolated power panel with enhancements). Use this page as a reference to help identify the components shown in the outline drawings on pages 10, 14, 19, and 24.

Typical Panel Components

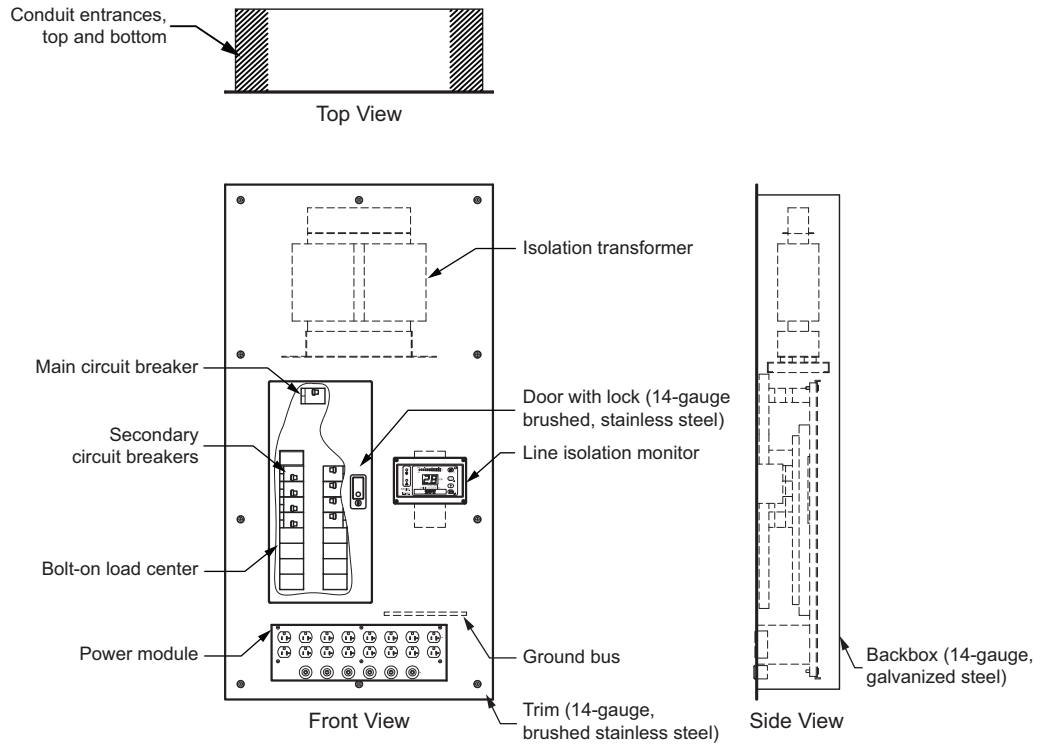

Features and Options

Standard Isolated Power Panel

- Iso-Gard Series 6 line isolation monitor
- Primary circuit breaker
- Eight 20 A, 2-pole, Square D™ brand branch circuit breakers
- Mounting provisions for eight additional 20 A, 2-pole circuit breakers
- Reference ground bar with 20 terminals
- Designed for 120 V applications
- Available in 3, 5, 7.5, and 10 kVA

Ideal for operating rooms or critical areas



Standard Panel Enhancements

- Field convertible up to (16) 20 A, 2-pole, Square D™ brand branch circuit breakers
- Receptacles
 - Red or ivory
 - Duplex or single
 - Twist-lock
- Power and ground modules
- Optional bolt-on circuit breakers

Allows for centralized location of receptacles and ground jacks



Accessories

- Power and ground modules
- Hospital-grade ground cords
- Remote indicator
- Remote annunciator stations

Configurations

Standard Isolated Power Panel							Enhancements	
kVA	Primary Voltage	Secondary Voltage	Mounting	Circuit Breakers	No. of 20 A, 2-pole Circuits	Ground Bar	120 V Receptacles	Ground Jacks
3	120				8 factory-installed		0–8	
5	208	120	Flush	Plug-on		Standard	Red or Ivory, Duplex or Single	0–8
7.5	240	208	Surface	Bolt-on	Up to 8 additional field-installed		L5–L20 twist lock	
10	277	240						
	480							

Medical Isolated Power Panels Standard Panels

Ordering Information

120 V Distribution

Transformer				Interior					Trim Catalog No.		Back Box Catalog No.	
kVA	Primary	Secondary	Catalog No.	LIM Included (field-installed)	Main Disconnect	Circuit Breakers (factory-installed)	Spaces	Catalog No.	Flush	Surface	Flush	Surface

Plug-on Circuit Breakers

3	208 V	120 V	SXM03BA	Iso-Gard Series 6	QOU220	Eight QO220	Eight 2-pole	SIP03BA	ST4526	ST4324	SB432406	SB432406S
3	240 V		SXM03CA					SIP03CA				
3	277 V		SXM03DA		SIP03DA							
5	208 V	120 V	SXM05BA	Iso-Gard Series 6	QOU230	Eight QO220	Eight 2-pole	SIP05BA	ST4526	ST4324	SB432406	SB432406S
5	240 V		SXM05CA					SIP05CA				
5	277 V		SXM05DA		SIP05DA							
5	480 V		SXM05EA		SIP05EA							
7.5	208 V	120 V	SXM07BA	Iso-Gard Series 6	QOU245	Eight QO220	Eight 2-pole	SIP07BA	ST4526	ST4324	SB432408	SB432408S
7.5	240 V		SXM07CA		QOU240			SIP07CA				
7.5	277 V		SXM07DA		HDL26035			SIP07DA				
7.5	480 V		SXM07EA		HDL26020			SIP07EA				
10	208 V	120 V	SXM10BA	Iso-Gard Series 6	QOU260	Eight QO220	Eight 2-pole	SIP10BA	ST4526	ST4324	SB432408	SB432408S
10	240 V		SXM10CA					SIP10CA				
10	277 V		SXM10DA		SIP10DA							
10	480 V		SXM10EA		SIP10EA							

Bolt-on Circuit Breakers

3	208 V	120 V	SXM03BA	Iso-Gard Series 6	QOU220	Eight QOB220	Eight 2-pole	SIP03BAB	ST4526	ST4324	SB432406	SB432406S
3	240 V		SXM03CA					SIP03CAB				
3	277 V		SXM03DA		SIP03DAB							
5	208 V	120 V	SXM05BA	Iso-Gard Series 6	QOU230	Eight QOB220	Eight 2-pole	SIP05BAB	ST4526	ST4324	SB432406	SB432406S
5	240 V		SXM05CA					SIP05CAB				
5	277 V		SXM05DA		SIP05DAB							
5	480 V		SXM05EA		SIP05EAB							
7.5	208 V	120 V	SXM07BA	Iso-Gard Series 6	QOU245	Eight QOB220	Eight 2-pole	SIP07BAB	ST4526	ST4324	SB432408	SB432408S
7.5	240 V		SXM07CA		QOU240			SIP07CAB				
7.5	277 V		SXM07DA		HDL26035			SIP07DAB				
7.5	480 V		SXM07EA		HDL26020			SIP07EAB				
10	208 V	120 V	SXM10BA	Iso-Gard Series 6	QOU260	Eight QOB220	Eight 2-pole	SIP10BAB	ST4526	ST4324	SB432408	SB432408S
10	240 V		SXM10CA					SIP10CAB				
10	277 V		SXM10DA		SIP10DAB							
10	480 V		SXM10EA		SIP10EAB							

Also available with factory-installed power modules. Options are:

- 1–8 receptacles: Red Duplex, Ivory Duplex, Red Single, Ivory Single, Black Twist Lock
- 1–8 ground modules

Wiring Diagram

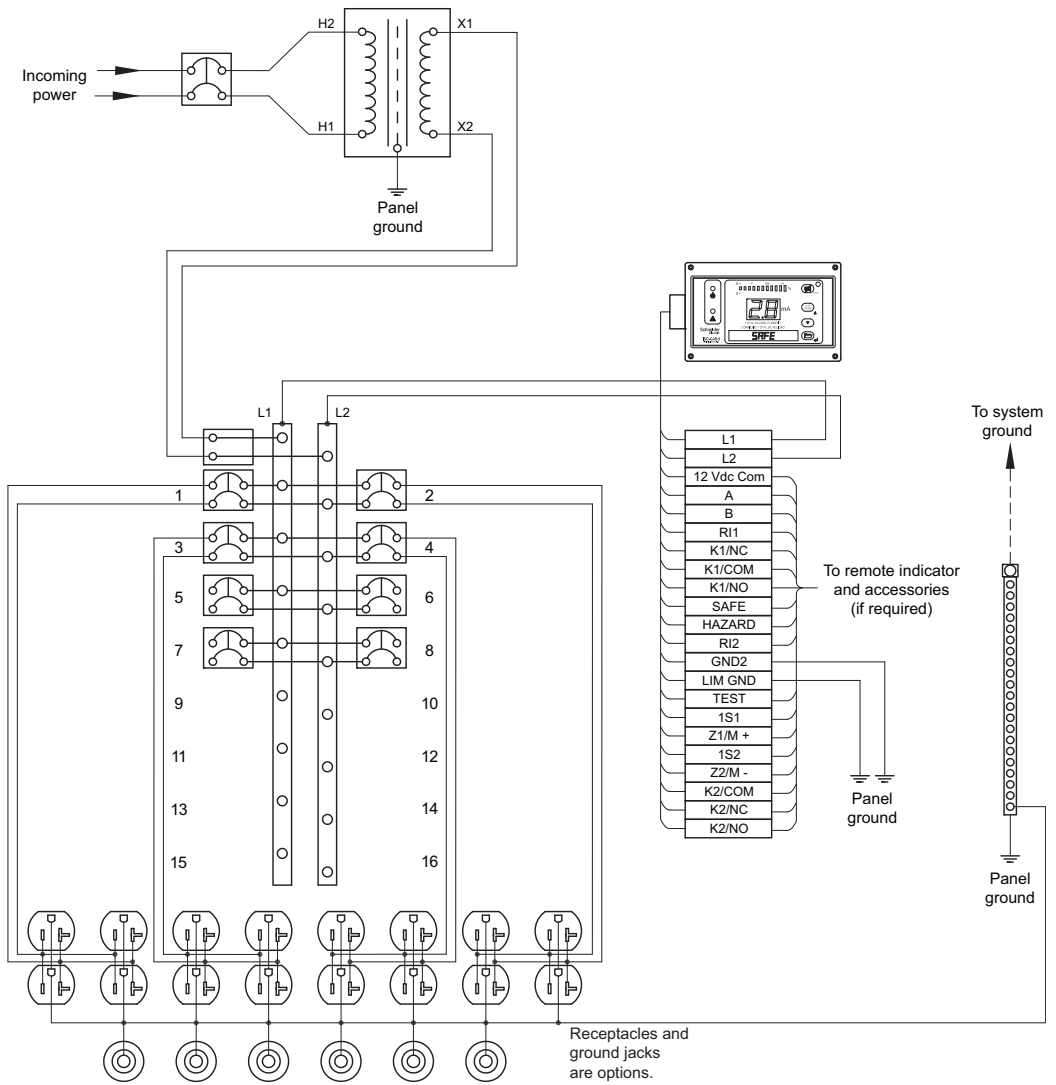

Medical Isolated Power Panels Standard Panels

Technical Data

Outline—Standard Isolated Power Panel

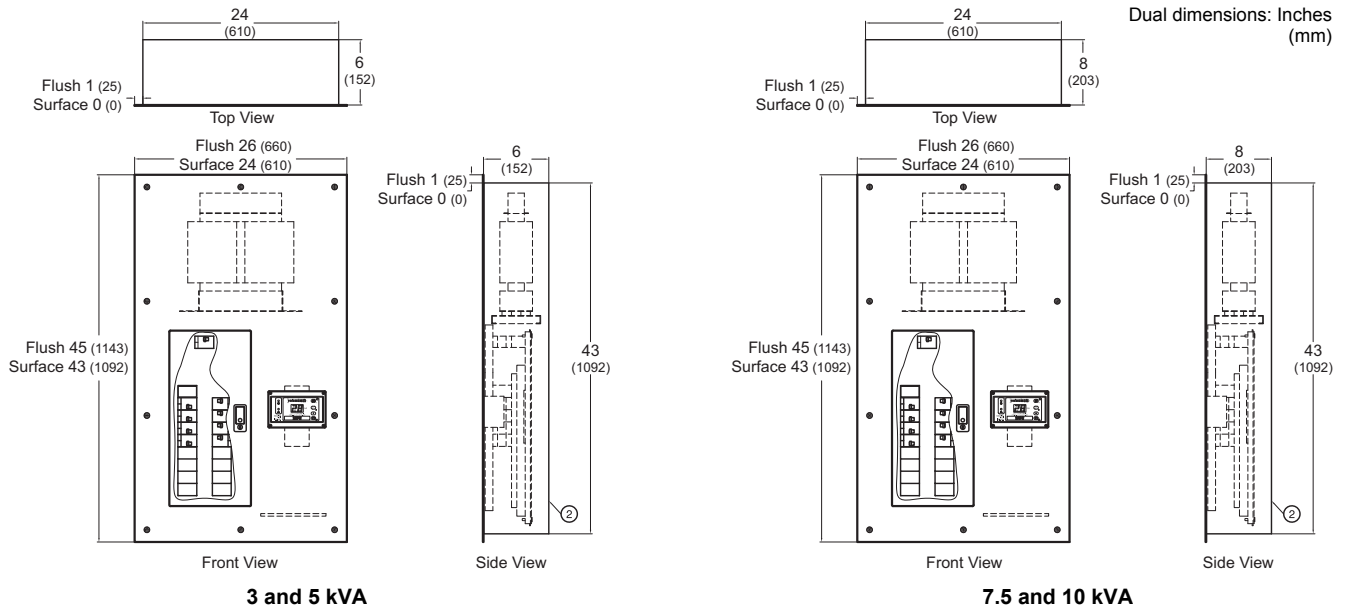

Outline—Standard Isolated Power Panel with Enhancements

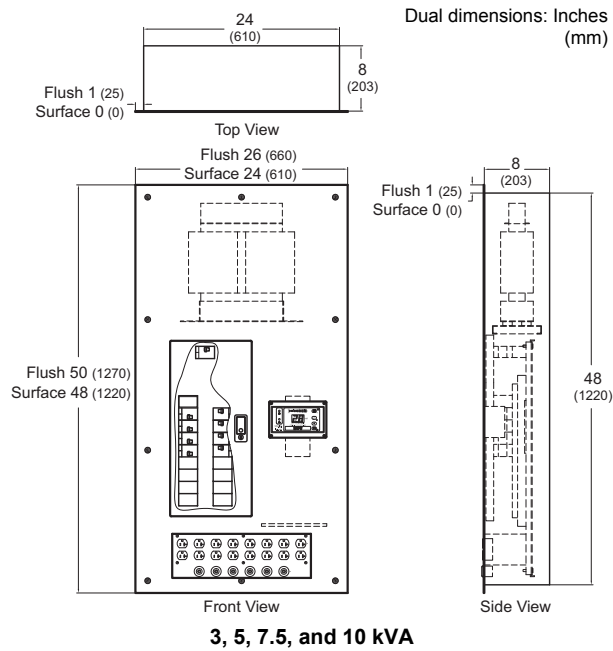

Features and Options

Duplex Operating Room Panels

Ideal for locations where space is limited, for renovations, or for minimizing leakage current on the individual panel and transformer.

Each panel features the following items:

- Iso-Gard™ Series 6 line isolation monitor
- Primary circuit breaker
- Eight Square D™ brand, 20 A, 2-pole, branch circuit breakers
- Mounting provisions for eight additional 20 A, 2-pole circuit breakers
- Reference ground bar with 20 terminals
- Designed for 120 V applications
- Available in 3, 5, 7.5, and 10 kVA

Duplex Panels—only one back box and trim piece required for two Isolated Power Systems

- Transformer—two required (one for each system)
- Interior—two mains, two LIMs, two panelboards, two ground bars mounted on one common back plate
- Single trim
- Single back box

All items must be ordered as separate line items.

Configurations

Duplex Operating Room Panel						
kVA	Primary Voltage	Secondary Voltage	Mounting	Circuit Breakers	No. of 20 A, 2-pole Circuits	Ground Bar
3	120					
5	208	120	Flush	Plug-on	8 factory-installed	Standard
7.5	240	208	Surface	Bolt-on	Up to 8 additional field-installed	
	277	240				
10	480					

- Back box for all duplex panels: Flush-mount—SB713408; Surface-mount—SB713408S
- Trim for all duplex panels: Flush-mount—ST7336; Surface-mount—ST7134
- Units are available in any combination of primary voltages and kVA ratings.

Medical Isolated Power Panels Duplex Panels

Ordering Information

120 V Distribution on Both Sides of the Panel

Transformer					Interior								Catalog No.
kVA	Primary	Secondary	Catalog No.		Left				Right				
			Left	Right	LIM Included (field-installed)	Main Disconnect	Circuit Breakers (factory-installed)	Spaces	LIM Included (field-installed)	Main Disconnect	Circuit Breakers (factory-installed)	Spaces	

Plug-on Circuit Breakers

3	208 V	120 V	SXM03BA	SXM03BA	Iso-Gard Series 6	QOU220	Eight QO220	Eight 2-pole	Iso-Gard Series 6	QOU220	Eight QO220	Eight 2-pole	SIX03BA03BA
3	240 V		SXM03CA	SXM03CA									HDL26015
3	277 V		SXM03DA	SXM03DA		HDL26015				HDL26015			SIX03DA03DA
5	208 V	120 V	SXM05BA	SXM05BA	Iso-Gard Series 6	QOU230	Eight QO220	Eight 2-pole	Iso-Gard Series 6	QOU230	Eight QO220	Eight 2-pole	SIX05BA05BA
5	240 V		SXM05CA	SXM05CA									HDL26025
5	277 V		SXM05DA	SXM05DA		HDL26015				HDL26015			SIX05DA05DA
5	480 V		SXM05EA	SXM05EA		HDL26015				HDL26015			SIX05EA05EA
7.5	208 V	120 V	SXM07BA	SXM07BA	Iso-Gard Series 6	QOU245	Eight QO220	Eight 2-pole	Iso-Gard Series 6	QOU245	Eight QO220	Eight 2-pole	SIX07BA07BA
7.5	240 V		SXM07CA	SXM07CA									HDL26035
7.5	277 V		SXM07DA	SXM07DA		HDL26020				HDL26020			SIX07DA07DA
7.5	480 V		SXM07EA	SXM07EA		HDL26020				HDL26020			SIX07EA07EA
10	208 V	120 V	SXM10BA	SXM10BA	Iso-Gard Series 6	QOU260	Eight QO220	Eight 2-pole	Iso-Gard Series 6	QOU260	Eight QO220	Eight 2-pole	SIX10BA10BA
10	240 V		SXM10CA	SXM10CA									HDL26045
10	277 V		SXM10DA	SXM10DA		HDL26030				HDL26030			SIX10DA10DA
10	480 V		SXM10EA	SXM10EA		HDL26030				HDL26030			SIX10EA10EA

Bolt-on Circuit Breakers

3	208 V	120 V	SXM03BA	SXM03BA	Iso-Gard Series 6	QOU220	Eight QOB220	Eight 2-pole	Iso-Gard Series 6	QOU220	Eight QOB220	Eight 2-pole	SIX03BA03BAB
3	240 V		SXM03CA	SXM03CA									HDL26015
3	277 V		SXM03DA	SXM03DA		HDL26015				HDL26015			SIX03DA03DAB
5	208 V	120 V	SXM05BA	SXM05BA	Iso-Gard Series 6	QOU230	Eight QOB220	Eight 2-pole	Iso-Gard Series 6	QOU230	Eight QOB220	Eight 2-pole	SIX05BA05BAB
5	240 V		SXM05CA	SXM05CA									HDL26025
5	277 V		SXM05DA	SXM05DA		HDL26015				HDL26015			SIX05DA05DAB
5	480 V		SXM05EA	SXM05EA		HDL26015				HDL26015			SIX05EA05EAB
7.5	208 V	120 V	SXM07BA	SXM07BA	Iso-Gard Series 6	QOU245	Eight QOB220	Eight 2-pole	Iso-Gard Series 6	QOU245	Eight QOB220	Eight 2-pole	SIX07BA07BAB
7.5	240 V		SXM07CA	SXM07CA									HDL26035
7.5	277 V		SXM07DA	SXM07DA		HDL26020				HDL26020			SIX07DA07DAB
7.5	480 V		SXM07EA	SXM07EA		HDL26020				HDL26020			SIX07EA07EAB
10	208 V	120 V	SXM10BA	SXM10BA	Iso-Gard Series 6	QOU260	Eight QOB220	Eight 2-pole	Iso-Gard Series 6	QOU260	Eight QOB220	Eight 2-pole	SIX10BA10BAB
10	240 V		SXM10CA	SXM10CA									HDL26045
10	277 V		SXM10DA	SXM10DA		HDL26030				HDL26030			SIX10DA10DAB
10	480 V		SXM10EA	SXM10EA		HDL26030				HDL26030			SIX10EA10EAB

NOTE: To complete the system, you must order the appropriate back box and trim from page 11.

Technical Data

Wiring Diagram

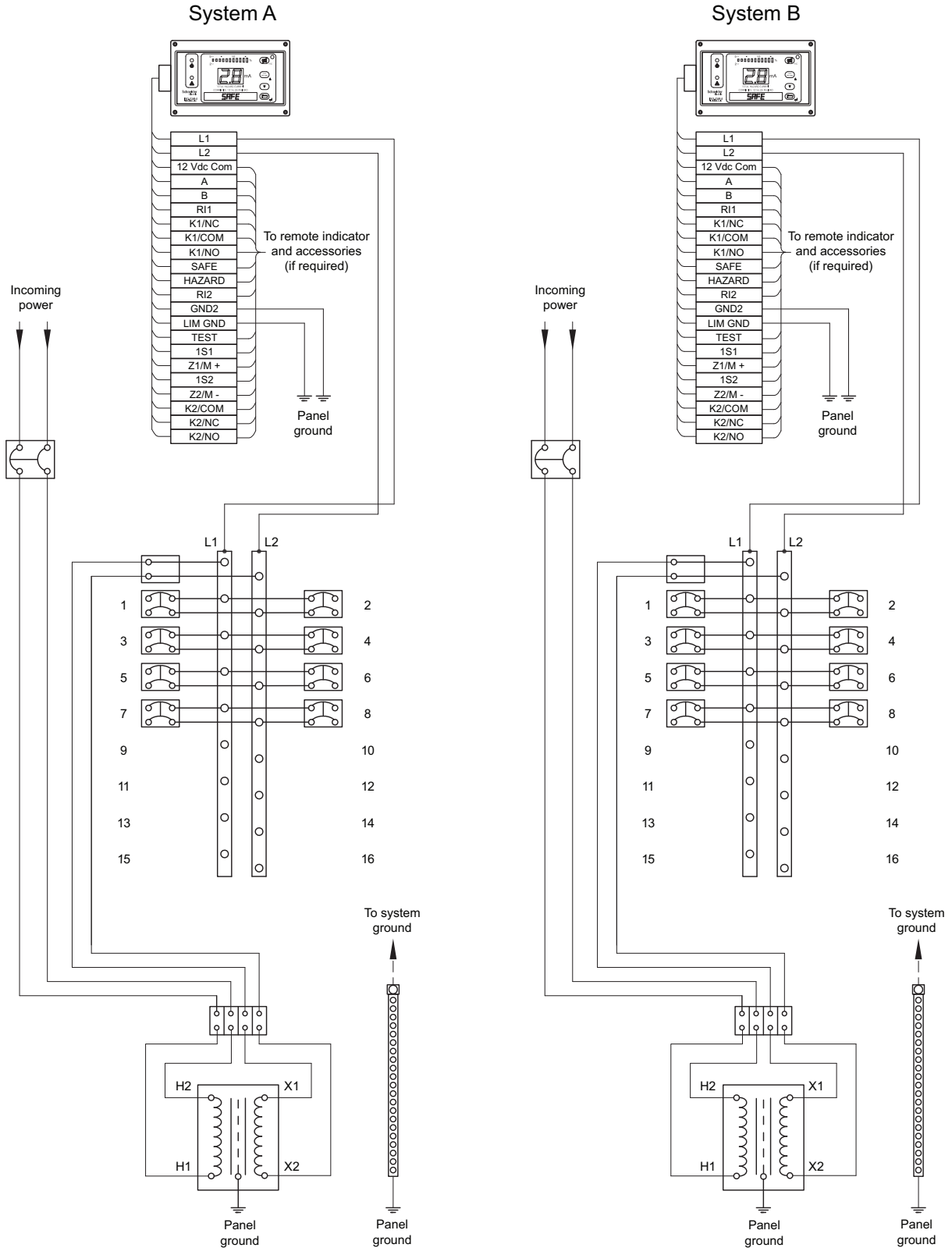

Medical Isolated Power Panels Duplex Panels

Technical Data

Outline

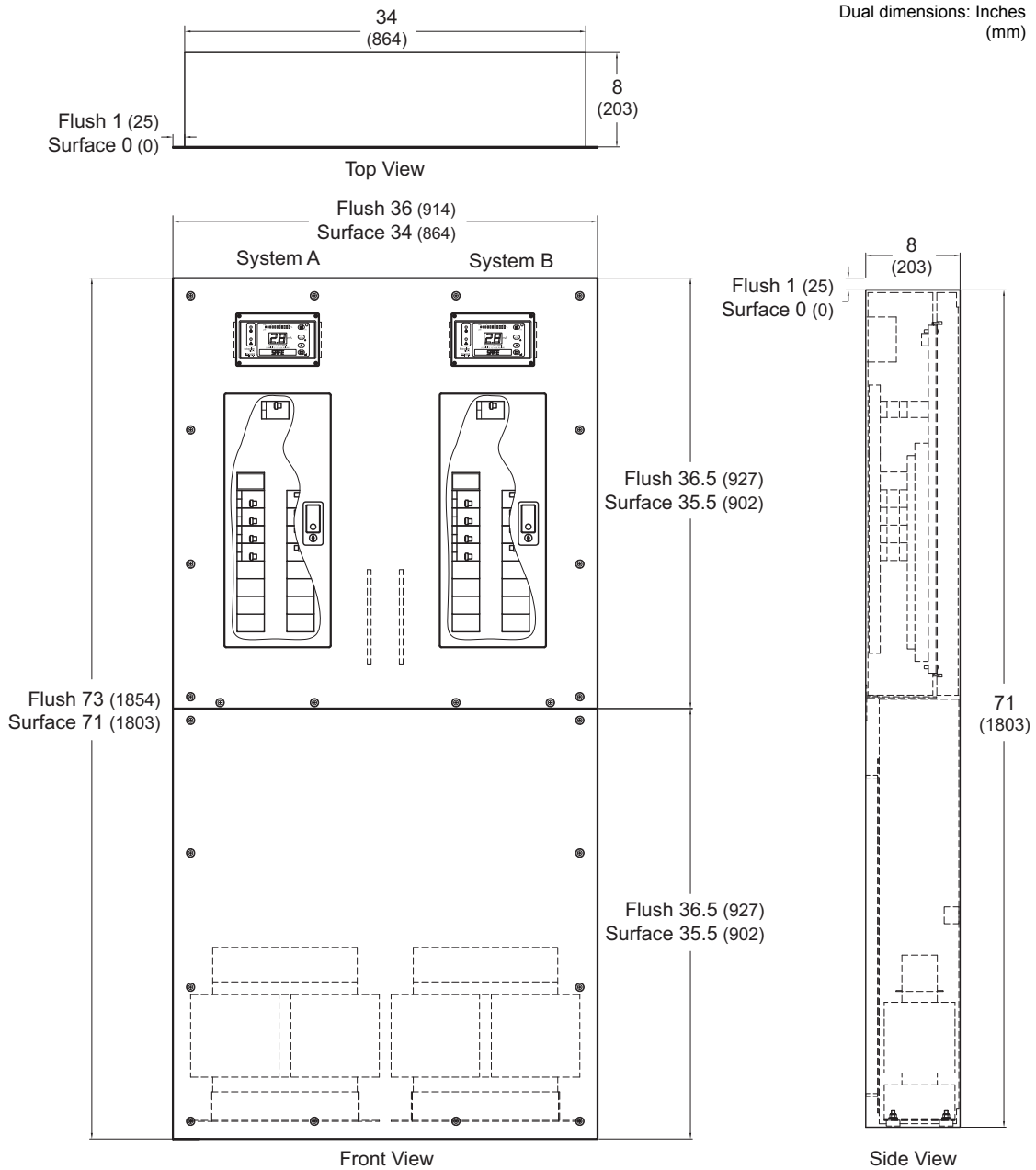

Dual Voltage Isolated Power Panels

Combines standard (120 V) and controlled (208 or 240 V) panels into one space-saving solution.

- Primary circuit breaker
- 120 V output
 - Iso-Gard Series 6 line isolation monitor
 - Eight Square D™ brand, 20 A, 2-pole, branch circuit breakers
 - Mounting provisions for eight additional 20 A, 2-pole circuit breakers
 - Reference ground bar with 20 terminals
 - Available in 3, 5, 7.5, and 10 kVA
 - Up to eight receptacles
 - Up to eight ground jacks
- 208 or 240 V output
 - Iso-Gard Series 6 line isolation monitor
 - Two Square D™ brand, 2-pole, branch circuit breakers
 - **Typical Layout of Branch Circuits:**
 - two 30 A circuit breakers
 - one 30 A circuit breaker, one 50 A circuit breaker
 - one 30 A circuit breaker, space only for second circuit breaker
 - one 50 A circuit breaker, space only for second circuit breaker
 - Reference ground bar with 20 terminals
 - Customized control to meet customer requirements
 - Available in 15 kVA
 - One or two laser outlets

Dual Voltage Panels—120 V distribution plus two circuits of 208V or 240V

kVA Ratings

5/15 kVA—20 kVA Primary, 5 kVA 120 V Secondary, 15 kVA 208 or 240 V Secondary

7.5/15 kVA—22.5 kVA Primary, 7.5 kVA 120 V Secondary, 15 kVA 208 or 240 V Secondary

10/15 kVA—25 kVA Primary, 10 kVA 120 V Secondary, 15 kVA 208 or 240 V Secondary

Options

- 208/240 branch circuits can be changed to any combination of 20, 30, 50, or 60 A circuit breakers. Please use the Product Selector to obtain the combination required.
- Available with factory-installed power modules.
 - Receptacle 0 to 8—Red Duplex, Ivory Duplex, Red Single, Ivory Single, Black Twist Lock
 - Ground modules 0 to 8
 - 208 V and 240 V receptacles
 - NEMA 6-15R, NEMA 6-20R, NEMA 6-30R, NEMA 6-50R
 - NEMA L6-15R, NEMA L6-20R, NEMA L6-30R
 - Hubbell CS8269, Hubbell IN16494

Medical Isolated Power Panels Dual Voltage Panels

Ordering Information

Transformer				Interior								Trim Catalog No.		Back Box Catalog No.	
kVA	Primary	Secondary	Catalog No.	LIM Included (field-installed)	Main Disconnect	120 V Panel Main Circuit Breakers	Circuit Breakers (factory-installed)	Spaces	208/240 V Main Circuit Breakers	208/240 V Branch Circuit Breakers	Catalog No.	Flush	Surface	Flush	Surface
Plug-on Circuit Breakers															
5/15	208	208/120	SXM25BB10	Iso-Gard Series 6	QOU2125	QOU250	Eight QO220	Eight 2-pole	QOU280	(1) QOU230 (1) QOU250	SID20BB05A31A51	ST5336	ST5134	SB513414	SB513414S
	240		SXM25CB10		QOU2100						SID20CB05A31A51				
	277		SXM25DB10		HDL26090						SID20DB05A31A51				
	480		SXM25EB10		HDL26050						SID20EB05A31A51				
7.5/15	208	208/120	SXM25BB10	Iso-Gard Series 6	QOU2150	QOU270	Eight QO220	Eight 2-pole	QOU280	(1) QOU230 (1) QOU250	SID22BB07A31A51	ST5336	ST5134	SB513414	SB513414S
	240		SXM25CB10		QOU2150						SID22CB07A31A51				
	277		SXM25DB10		HDL26125						SID22DB07A31A51				
	480		SXM25EB10		HDL26070						SID22EB07A31A51				
10/15	208	208/120	SXM25BB10	Iso-Gard Series 6	QOU2150	QOU2100	Eight QO220	Eight 2-pole	QOU280	(1) QOU230 (1) QOU250	SID25BB10A31A51	ST5336	ST5134	SB513414	SB513414S
	240		SXM25CB10		QOU2150						SID25CB10A31A51				
	277		SXM25DB10		HDL26125						SID25DB10A31A51				
	480		SXM25EB10		HDL26070						SID25EB10A31A51				
5/15	208	240/120	SXM25BC10	Iso-Gard Series 6	QOU2125	QOU250	Eight QO220	Eight 2-pole	QOU270	(1) QOU230 (1) QOU250	SID20BC05A31A51	ST5336	ST5134	SB513414	SB513414S
	240		SXM25CC10		QOU2100						SID20CC05A31A51				
	277		SXM25DC10		HDL26090						SID20DC05A31A51				
	480		SXM25EC10		HDL26050						SID20EC05A31A51				
7.5/15	208	240/120	SXM25BC10	Iso-Gard Series 6	QOU2150	QOU270	Eight QO220	Eight 2-pole	QOU270	(1) QOU230 (1) QOU250	SID22BC07A31A51	ST5336	ST5134	SB513414	SB513414S
	240		SXM25CC10		QOU2150						SID22CC07A31A51				
	277		SXM25DC10		HDL26125						SID22DC07A31A51				
	480		SXM25EC10		HDL26070						SID22EC07A31A51				
10/15	208	240/120	SXM25BC10	Iso-Gard Series 6	QOU2150	QOU2100	Eight QO220	Eight 2-pole	QOU270	(1) QOU230 (1) QOU250	SID25BC10A31A51	ST5336	ST5134	SB513414	SB513414S
	240		SXM25CC10		QOU2150						SID25CC10A31A51				
	277		SXM25DC10		HDL26125						SID25DC10A31A51				
	480		SXM25EC10		HDL26070						SID25EC10A31A51				
Bolt-on Circuit Breakers															
5/15	208	208/120	SXM25BB10	Iso-Gard Series 6	QOU2125	QOU250	Eight QOB220	Eight 2-pole	QOU280	(1) QOU230 (1) QOU250	SID20BB05BA31A51	ST5336	ST5134	SB513414	SB513414S
	240		SXM25CB10		QOU2100						SID20CB05BA31A51				
	277		SXM25DB10		HDL26090						SID20DB05BA31A51				
	480		SXM25EB10		HDL26050						SID20EB05BA31A51				
7.5/15	208	208/120	SXM25BB10	Iso-Gard Series 6	QOU2150	QOU270	Eight QOB220	Eight 2-pole	QOU280	(1) QOU230 (1) QOU250	SID22BB07BA31A51	ST5336	ST5134	SB513414	SB513414S
	240		SXM25CB10		QOU2150						SID22CB07BA31A51				
	277		SXM25DB10		HDL26125						SID22DB07BA31A51				
	480		SXM25EB10		HDL26070						SID22EB07BA31A51				
10/15	208	208/120	SXM25BB10	Iso-Gard Series 6	QOU2150	QOU2100	Eight QOB220	Eight 2-pole	QOU280	(1) QOU230 (1) QOU250	SID25BB10BA31A51	ST5336	ST5134	SB513414	SB513414S
	240		SXM25CB10		QOU2150						SID25CB10BA31A51				
	277		SXM25DB10		HDL26125						SID25DB10BA31A51				
	480		SXM25EB10		HDL26070						SID25EB10BA31A51				
5/15	208	240/120	SXM25BC10	Iso-Gard Series 6	QOU2125	QOU250	Eight QOB220	Eight 2-pole	QOU270	(1) QOU230 (1) QOU250	SID20BC05BA31A51	ST5336	ST5134	SB513414	SB513414S
	240		SXM25CC10		QOU2100						SID20CC05BA31A51				
	277		SXM25DC10		HDL26090						SID20DC05BA31A51				
	480		SXM25EC10		HDL26050						SID20EC05BA31A51				
7.5/15	208	240/120	SXM25BC10	Iso-Gard Series 6	QOU2150	QOU270	Eight QOB220	Eight 2-pole	QOU270	(1) QOU230 (1) QOU250	SID22BC07BA31A51	ST5336	ST5134	SB513414	SB513414S
	240		SXM25CC10		QOU2150						SID22CC07BA31A51				
	277		SXM25DC10		HDL26125						SID22DC07BA31A51				
	480		SXM25EC10		HDL26070						SID22EC07BA31A51				
10/15	208	240/120	SXM25BC10	Iso-Gard Series 6	QOU2150	QOU2100	Eight QOB220	Eight 2-pole	QOU270	(1) QOU230 (1) QOU250	SID25BC10BA31A51	ST5336	ST5134	SB513414	SB513414S
	240		SXM25CC10		QOU2150						SID25CC10BA31A51				
	277		SXM25DC10		HDL26125						SID25DC10BA31A51				
	480		SXM25EC10		HDL26070						SID25EC10BA31A51				

Medical Isolated Power Panels Dual Voltage Panels

Ordering Information

Transformer				Interior								Trim Catalog No.		Back Box Catalog No.	
kVA	Primary	Secondary	Catalog No.	LIM Included (field-installed)	Main Disconnect	120 V Panel Main Circuit Breakers	Circuit Breakers (factory-installed)	Spaces	208/240 V Main Circuit Breakers	208/240 V Branch Circuit Breakers	Catalog No.	Flush	Surface	Flush	Surface
Plug-on Circuit Breakers															
5/15	208	208/120	SXM25BB10	Iso-Gard Series 6	QOU2125	QOU250	Eight QO220	Eight 2-pole	QOU280	(2) QOU230	SID20BB05A32	ST5336	ST5134	SB513414	SB513414S
	240		SXM25CB10		QOU2100						SID20CB05A32				
	277		SXM25DB10		HDL26090						SID20DB05A32				
	480		SXM25EB10		HDL26050						SID20EB05A32				
7.5/15	208	208/120	SXM25BB10	Iso-Gard Series 6	QOU2150	QOU270	Eight QO220	Eight 2-pole	QOU280	(2) QOU230	SID22BB07A32	ST5336	ST5134	SB513414	SB513414S
	240		SXM25CB10		QOU2150						SID22CB07A32				
	277		SXM25DB10		HDL26125						SID22DB07A32				
	480		SXM25EB10		HDL26070						SID22EB07A32				
10/15	208	208/120	SXM25BB10	Iso-Gard Series 6	QOU2150	QOU2100	Eight QO220	Eight 2-pole	QOU280	(2) QOU230	SID25BB10A32	ST5336	ST5134	SB513414	SB513414S
	240		SXM25CB10		QOU2150						SID25CB10A32				
	277		SXM25DB10		HDL26125						SID25DB10A32				
	480		SXM25EB10		HDL26070						SID25EB10A32				
5/15	208	240/120	SXM25BC10	Iso-Gard Series 6	QOU2125	QOU250	Eight QO220	Eight 2-pole	QOU270	(2) QOU230	SID20BC05A32	ST5336	ST5134	SB513414	SB513414S
	240		SXM25CC10		QOU2100						SID20CC05A32				
	277		SXM25DC10		HDL26090						SID20DC05A32				
	480		SXM25EC10		HDL26050						SID20EC05A32				
7.5/15	208	240/120	SXM25BC10	Iso-Gard Series 6	QOU2150	QOU270	Eight QO220	Eight 2-pole	QOU270	(2) QOU230	SID22BC07A32	ST5336	ST5134	SB513414	SB513414S
	240		SXM25CC10		QOU2150						SID22CC07A32				
	277		SXM25DC10		HDL26125						SID22DC07A32				
	480		SXM25EC10		HDL26070						SID22EC07A32				
10/15	208	240/120	SXM25BC10	Iso-Gard Series 6	QOU2150	QOU2100	Eight QO220	Eight 2-pole	QOU270	(2) QOU230	SID25BC10A32	ST5336	ST5134	SB513414	SB513414S
	240		SXM25CC10		QOU2150						SID25CC10A32				
	277		SXM25DC10		HDL26125						SID25DC10A32				
	480		SXM25EC10		HDL26070						SID25EC10A32				
Bolt-on Circuit Breakers															
5/15	208	208/120	SXM25BB10	Iso-Gard Series 6	QOU2125	QOU250	Eight QOB220	Eight 2-pole	QOU280	(2) QOU230	SID20BB05BA32	ST5336	ST5134	SB513414	SB513414S
	240		SXM25CB10		QOU2100						SID20CB05BA32				
	277		SXM25DB10		HDL26090						SID20DB05BA32				
	480		SXM25EB10		HDL26050						SID20EB05BA32				
7.5/15	208	208/120	SXM25BB10	Iso-Gard Series 6	QOU2150	QOU270	Eight QOB220	Eight 2-pole	QOU280	(2) QOU230	SID22BB07BA32	ST5336	ST5134	SB513414	SB513414S
	240		SXM25CB10		QOU2150						SID22CB07BA32				
	277		SXM25DB10		HDL26125						SID22DB07BA32				
	480		SXM25EB10		HDL26070						SID22EB07BA32				
10/15	208	208/120	SXM25BB10	Iso-Gard Series 6	QOU2150	QOU2100	Eight QOB220	Eight 2-pole	QOU280	(2) QOU230	SID25BB10BA32	ST5336	ST5134	SB513414	SB513414S
	240		SXM25CB10		QOU2150						SID25CB10BA32				
	277		SXM25DB10		HDL26125						SID25DB10BA32				
	480		SXM25EB10		HDL26070						SID25EB10BA32				
5/15	208	240/120	SXM25BC10	Iso-Gard Series 6	QOU2125	QOU250	Eight QOB220	Eight 2-pole	QOU270	(2) QOU230	SID20BC05BA32	ST5336	ST5134	SB513414	SB513414S
	240		SXM25CC10		QOU2100						SID20CC05BA32				
	277		SXM25DC10		HDL26090						SID20DC05BA32				
	480		SXM25EC10		HDL26050						SID20EC05BA32				
7.5/15	208	240/120	SXM25BC10	Iso-Gard Series 6	QOU2150	QOU270	Eight QOB220	Eight 2-pole	QOU270	(2) QOU230	SID22BC07BA32	ST5336	ST5134	SB513414	SB513414S
	240		SXM25CC10		QOU2150						SID22CC07BA32				
	277		SXM25DC10		HDL26125						SID22DC07BA32				
	480		SXM25EC10		HDL26070						SID22EC07BA32				
10/15	208	240/120	SXM25BC10	Iso-Gard Series 6	QOU2150	QOU2100	Eight QOB220	Eight 2-pole	QOU270	(2) QOU230	SID25BC10BA32	ST5336	ST5134	SB513414	SB513414S
	240		SXM25CC10		QOU2150						SID25CC10BA32				
	277		SXM25DC10		HDL26125						SID25DC10BA32				
	480		SXM25EC10		HDL26070						SID25EC10BA32				

Wiring Diagram

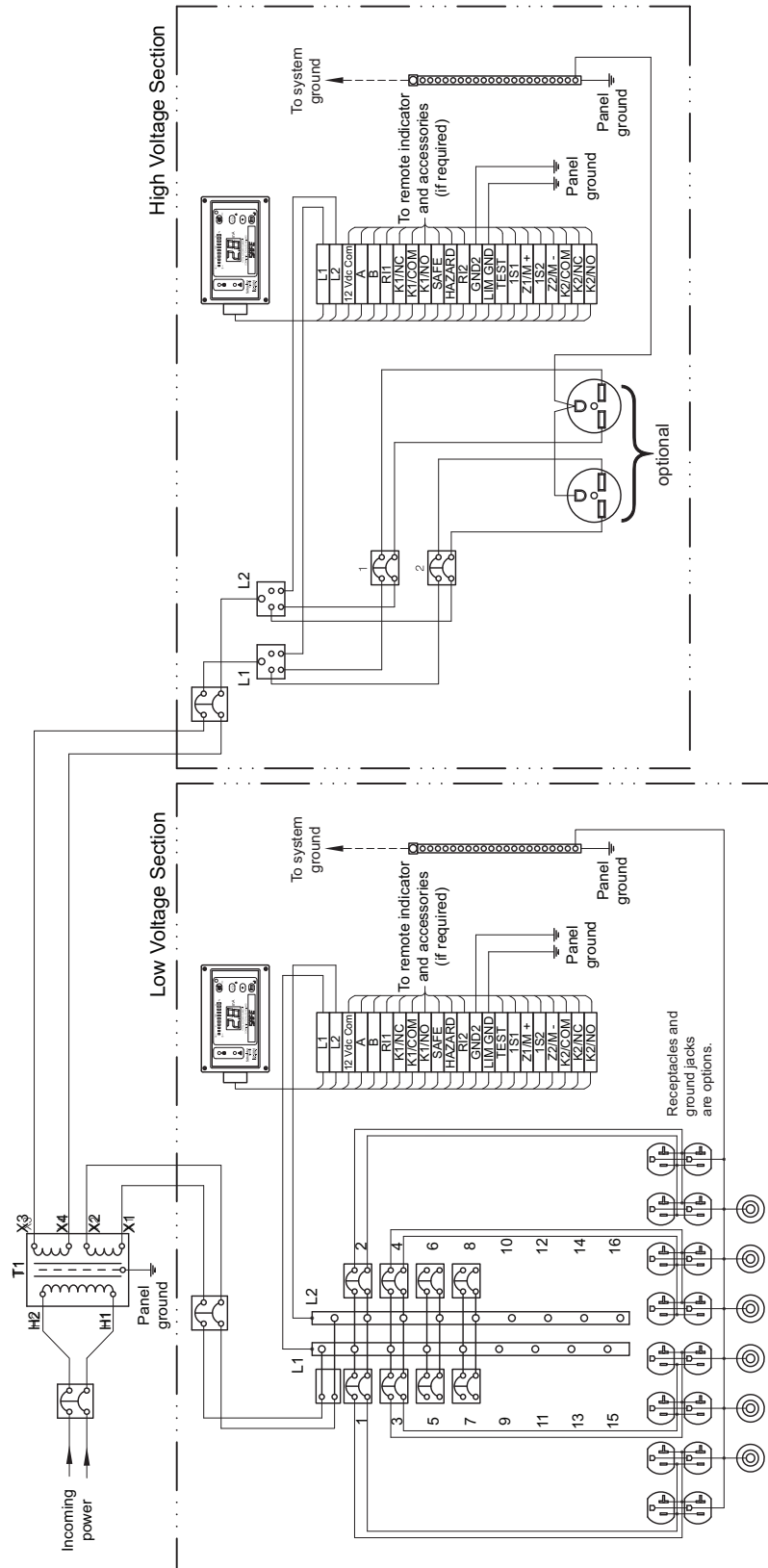

Technical Data

Medical Isolated Power Panels Dual Voltage Panels

Outlines

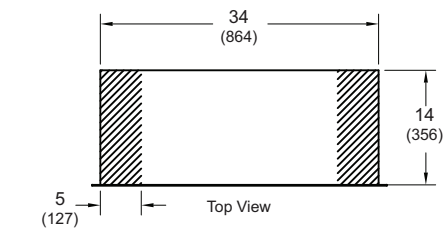

Dual dimensions: Inches
(mm)

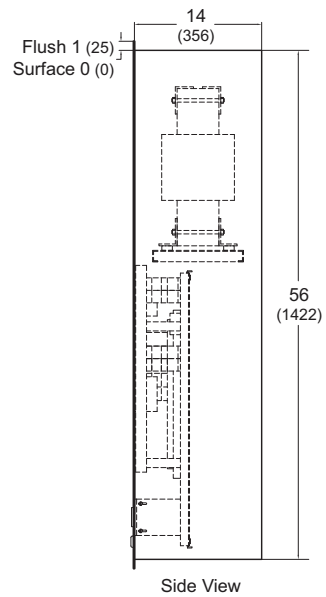
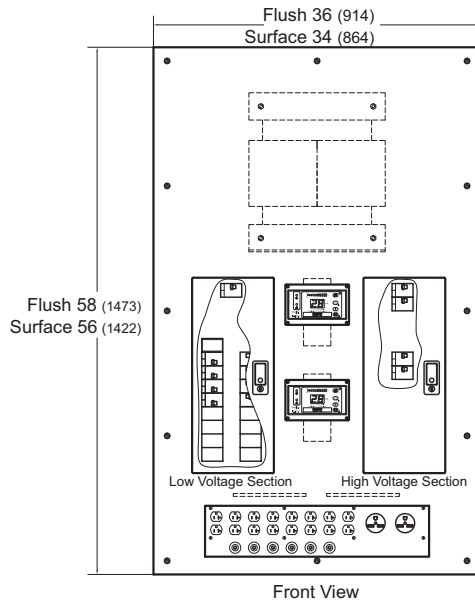
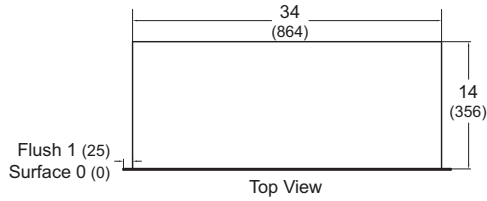
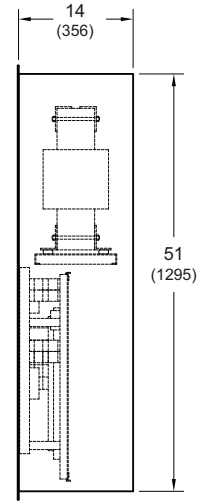
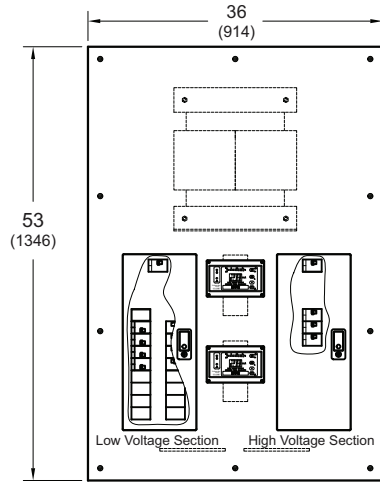

Controlled Isolated Power Panels

Panels with circuit control have a secondary circuit breaker that is connected to a maximum of eight branch circuits. The configuration of which circuits receive power is made at the factory to meet customer requirements. The selection of a secondary circuit is typically door-contact-controlled at the individual receptacle station or from a push button station built into the isolated power panel. No power will be delivered to a secondary circuit until the secondary breaker is closed.

- Iso-Gard Series 6 line isolation monitor
- Primary circuit breaker
- Eight Square D™ brand, 20 A, 2-pole, branch circuit breakers
- Mounting provisions for eight additional 20 A, 2-pole circuit breakers
- Reference ground bar with 20 terminals
- Designed for 208 or 240 V applications
- Customized control to meet customer requirements
- Available in 7.5, 10, 15, or 25 kVA
- Ideal for X-ray and laser equipment; control option is available for supplying power to portable equipment
- Customized control option—programmable logic controller (PLC) to interface with the 208/240 V receptacle module accessory

Configurations

Controlled Isolated Power Panel								X-Ray Module		
kVA	Primary Voltage	Secondary Voltage	Mounting	Type of Control PLC	No. of Laser Circuits	No. of Hot Circuits	Secondary Breaker	Quantity	Mounting	Type of Power Receptacle
7.5	208	208 240	Flush Surface	Door contact with lamp Door contact without lamp	1-8	1-6	20 A 30 A 50 A 60 A	Match circuits	Recessed Surface	NEMA #6-15R or #L6-15R
10	240									NEMA #6-20R or #L6-20R
15	277									NEMA #6-30R or #L6-30R
25	480									NEMA #6-50R Hubbel #IN16494

Units are available in other combinations of branch breakers, simultaneous circuits are limited to the number shown in the following table.

kVA	Secondary Voltage	Maximum Number of Branch Circuits			
		20 A	30 A	50 A	60 A
5	208	1	1	0	0
	240	1	1	0	0
7.5	208	2	1	0	0
	240	1	1	0	0
10	208	2	1	1	0
	240	2	1	1	0
15	208	4	2	1	2
	240	3	2	1	2
25	208	6	4	2	2
	240	6	4	2	2

NOTE: Also available with 240 V secondary.

Ordering Information

Door Interlock without In-Use Light

Transformer				Interior					Trim Catalog No.		Back Box Catalog No.	
kVA	Primary	Secondary	Catalog No.	LIM Included (field-installed)	Main Disconnect	Circuit Breakers (factory-installed)	Simultaneous Circuits PLC Controlled	Catalog No.	Flush	Surface	Flush	Surface
10	208	208	SXM10BB	Iso-Gard Series 6	QOU260	Four QO230	1	SIP10BBPNA34H1	ST5332	ST5130	SB513012	SB513012S
	240		SXM10CB		QOU260			SIP10CBPNA34H1				
	277		SXM10DB		HDL26045			SIP10DBPNA34H1				
	480		SXM10EB		HDL26030			SIP10EBPNA34H1				
10	208	208	SXM10BB	Iso-Gard Series 6	QOU260	Eight QO230	1	SIP10BBPNA38H1	ST5332	ST5130	SB513012	SB513012S
	240		SXM10CB		QOU260			SIP10CBPNA38H1				
	277		SXM10DB		HDL26045			SIP10DBPNA38H1				
	480		SXM10EB		HDL26030			SIP10EBPNA38H1				
10	208	208	SXM10BB	Iso-Gard Series 6	QOU260	Two QO250	1	SIP10BBPNA52H1	ST5332	ST5130	SB513012	SB513012S
	240		SXM10CB		QOU260			SIP10CBPNA52H1				
	277		SXM10DB		HDL26045			SIP10DBPNA52H1				
	480		SXM10EB		HDL26030			SIP10EBPNA52H1				
10	208	208	SXM10BB	Iso-Gard Series 6	QOU260	Four QO250	1	SIP10BBPNA54H1	ST5332	ST5130	SB513012	SB513012S
	240		SXM10CB		QOU260			SIP10CBPNA54H1				
	277		SXM10DB		HDL26045			SIP10DBPNA54H1				
	480		SXM10EB		HDL26030			SIP10EBPNA54H1				
15	208	208	SXM15BB	Iso-Gard Series 6	QOU290	Two QO250	1	SIP15BBPNA52H1	ST5332	ST5130	SB513012	SB513012S
	240		SXM15CB		QOU280			SIP15CBPNA52H1				
	277		SXM15DB		HDL26070			SIP15DBPNA52H1				
	480		SXM15EB		HDL26040			SIP15EBPNA52H1				
15	208	208	SXM15BB	Iso-Gard Series 6	QOU290	Four QO250	1	SIP15BBPNA54H1	ST5332	ST5130	SB513012	SB513012S
	240		SXM15CB		QOU280			SIP15CBPNA54H1				
	277		SXM15DB		HDL26070			SIP15DBPNA54H1				
	480		SXM15EB		HDL26040			SIP15EBPNA54H1				
15	208	208	SXM15BB	Iso-Gard Series 6	QOU290	One QO250 One QO230	1	SIP15BBPNA31A51H1	ST5332	ST5130	SB513012	SB513012S
	240		SXM15CB		QOU280			SIP15CBPNA31A51H1				
	277		SXM15DB		HDL26070			SIP15DBPNA31A51H1				
	480		SXM15EB		HDL26040			SIP15EBPNA31A51H1				

Medical Isolated Power Panels Controlled Panels

Ordering Information

Door Interlock with In-Use Light

Transformer				Interior					Trim Catalog No.		Back Box Catalog No.	
kVA	Primary	Secondary	Catalog No.	LIM Included (field-installed)	Main Disconnect	Circuit Breakers (factory-installed)	Simultaneous Circuits PLC Controlled	Catalog No.	Flush	Surface	Flush	Surface
10	208	208	SXM10BB	Iso-Gard Series 6	QOU260	Four QO230	1	SIP10BBPUA34H1	ST5332	ST5130	SB513012	SB513012S
	240		SXM10CB		QOU260			SIP10CBPUA34H1				
	277		SXM10DB		HDL26045			SIP10DBPUA34H1				
	480		SXM10EB		HDL26030			SIP10EBPUA34H1				
10	208	208	SXM10BB	Iso-Gard Series 6	QOU260	Eight QO230	1	SIP10BBPUA38H1	ST5332	ST5130	SB513012	SB513012S
	240		SXM10CB		QOU260			SIP10CBPUA38H1				
	277		SXM10DB		HDL26045			SIP10DBPUA38H1				
	480		SXM10EB		HDL26030			SIP10EBPUA38H1				
10	208	208	SXM10BB	Iso-Gard Series 6	QOU260	Two QO250	1	SIP10BBPUA52H1	ST5332	ST5130	SB513012	SB513012S
	240		SXM10CB		QOU260			SIP10CBPUA52H1				
	277		SXM10DB		HDL26045			SIP10DBPUA52H1				
	480		SXM10EB		HDL26030			SIP10EBPUA52H1				
10	208	208	SXM10BB	Iso-Gard Series 6	QOU260	Four QO250	1	SIP10BBPUA54H1	ST5332	ST5130	SB513012	SB513012S
	240		SXM10CB		QOU260			SIP10CBPUA54H1				
	277		SXM10DB		HDL26045			SIP10DBPUA54H1				
	480		SXM10EB		HDL26030			SIP10EBPUA54H1				
15	208	208	SXM15BB	Iso-Gard Series 6	QOU290	Two QO250	1	SIP15BBPUA52H1	ST5332	ST5130	SB513012	SB513012S
	240		SXM15CB		QOU280			SIP15CBPUA52H1				
	277		SXM15DB		HDL26070			SIP15DBPUA52H1				
	480		SXM15EB		HDL26040			SIP15EBPUA52H1				
15	208	208	SXM15BB	Iso-Gard Series 6	QOU290	Four QO250	1	SIP15BBPUA54H1	ST5332	ST5130	SB513012	SB513012S
	240		SXM15CB		QOU280			SIP15CBPUA54H1				
	277		SXM15DB		HDL26070			SIP15DBPUA54H1				
	480		SXM15EB		HDL26040			SIP15EBPUA54H1				
15	208	208	SXM15BB	Iso2 -Gard Series 6	QOU290	One QO250	1	SIP15BBPUA31A51H1	ST5332	ST5130	SB513012	SB513012S
	240		SXM15CB		QOU280			SIP15CBPUA31A51H1				
	277		SXM15DB		HDL26070	SIP15DBPUA31A51H1						
	480		SXM15EB		HDL26040	SIP15EBPUA31A51H1						

Technical Data

Wiring Diagram

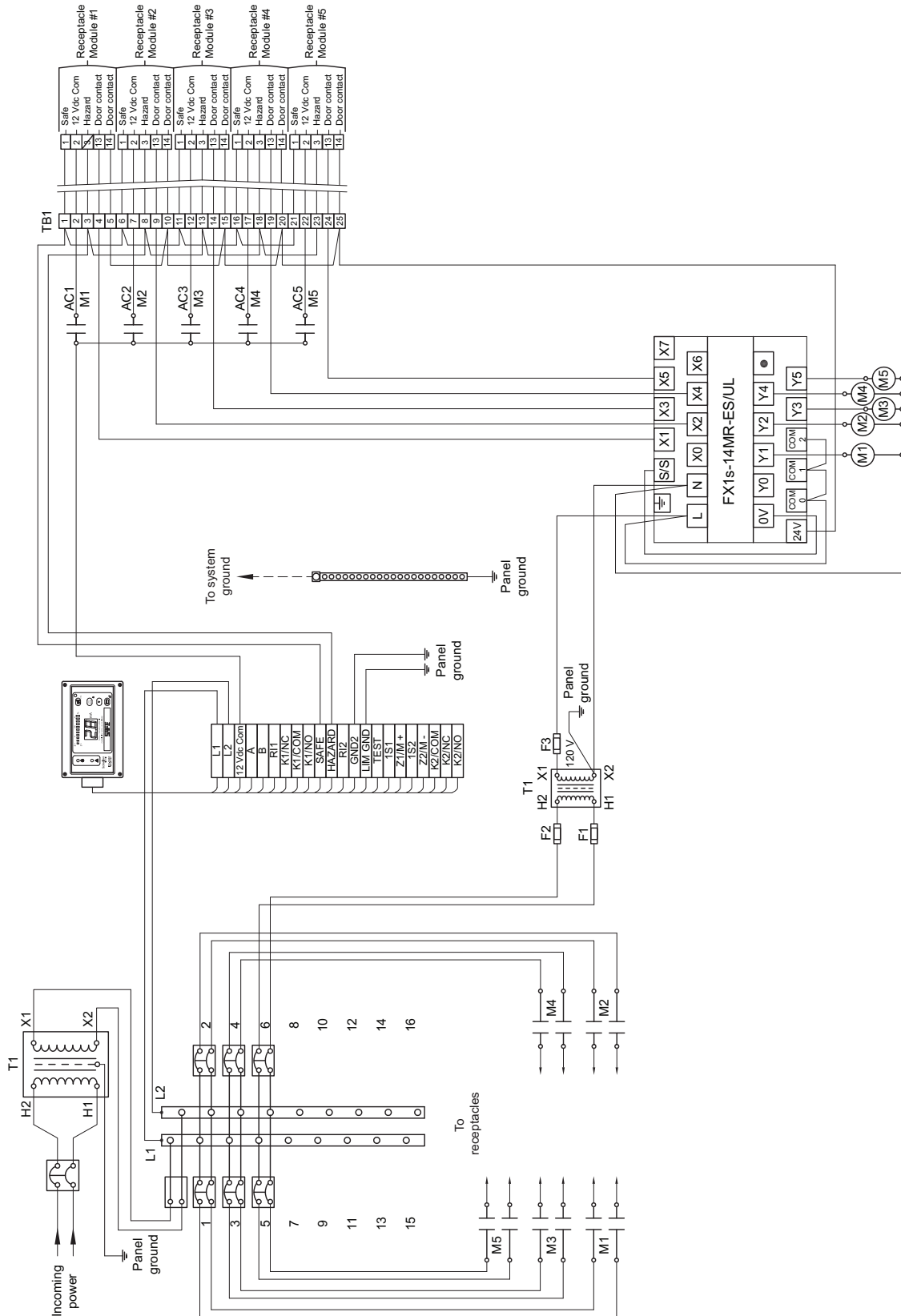

Outline

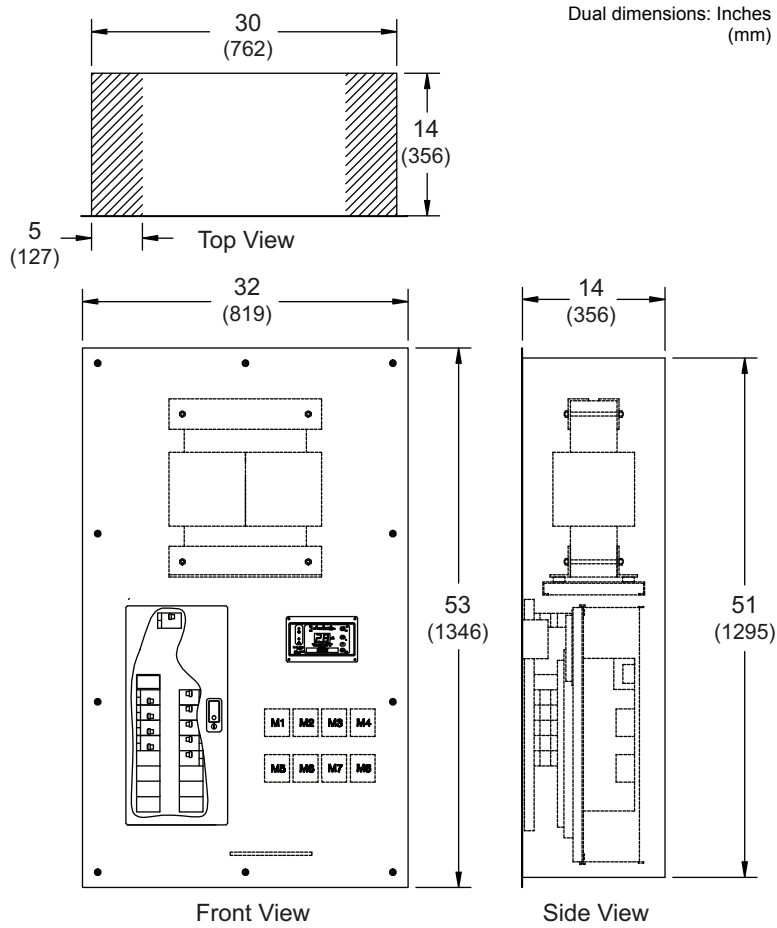

PLC Control Panel, Factory-Wired for Eight Circuits

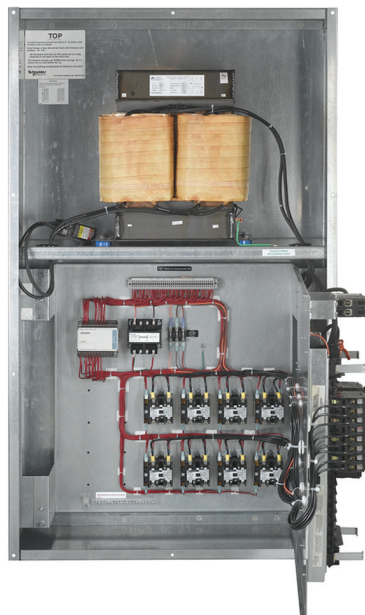

Features and Options

Medical Isolated Power Panels X-Ray/Power Receptacle Modules

X-ray/laser power receptacle modules from Schneider Electric provide a convenient source of power for portable X-ray and laser equipment. The hospital-grade receptacle provided in each module is matched to the NEMA plug configuration of the equipment with which it will be used. The recessed power receptacle is mounted behind the door on the stainless steel faceplate. The door features a concealed hinge and a touch latch.





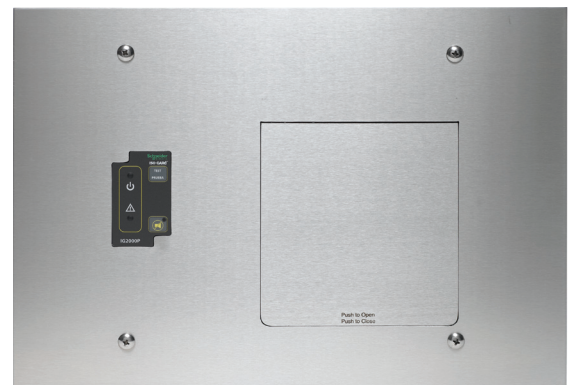
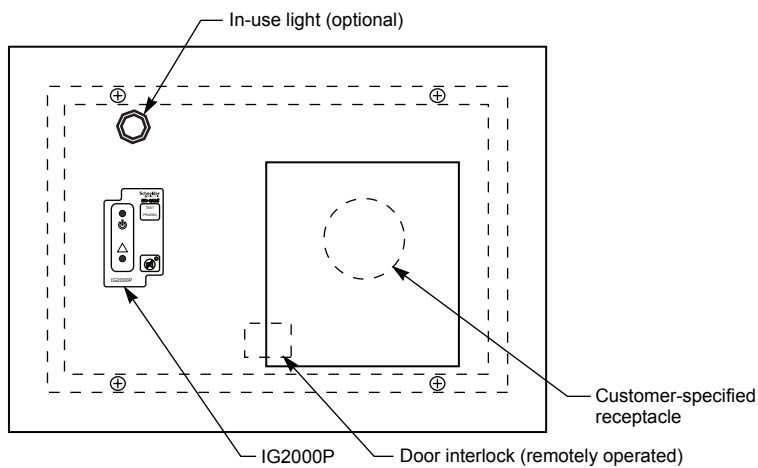





- Designed for flush- or surface-mounted applications
- Available options:
 - Iso-Gard™ IG2000P remote indicator
 - “In-use” lamp; when illuminated, indicates the receptacle cannot be used
 - Door contact (limit switch)
- UL Listed (UL1047)
- Five-year limited warranty



Customer-Specified Receptacles

250 V Grounding Devices

Ampere Ratings	Receptacle Configuration		
	Straight Blade	Locking	Hubbell
15	 NEMA 6-15R	 NEMA L6-15R	
20	 NEMA 6-20R	 NEMA L6-20R	
30	 NEMA 6-30R	 NEMA L6-30R	
50	 NEMA 6-50R		 CS8269
60			 IN16494

Description	Catalog No.	Back Box Catalog No.
Flush-mounted, IG2000P installed, receptacle Hubbell IN16494	SXRM1A1F	SB120804
Flush-mounted, IG2000P installed, receptacle NEMA 6-15R	SXRM2A1F	
Flush-mounted, IG2000P installed, receptacle NEMA 6-20R	SXRM3A1F	
Flush-mounted, IG2000P installed, receptacle NEMA 6-30R	SXRM4A1F	
Flush-mounted, IG2000P installed, receptacle NEMA 6-50R	SXRM5A1F	
Flush-mounted, IG2000P installed, receptacle NEMA L6-15R	SXRM6A1F	
Flush-mounted, IG2000P installed, receptacle NEMA L6-20R	SXRM7A1F	
Flush-mounted, IG2000P installed, receptacle NEMA L6-30R	SXRM8A1F	
Flush-mounted, IG2000P installed, receptacle Hubbell CS8269	SXRM9A1F	
Flush-mounted, IG2000P installed, receptacle Hubbell IN16494, in-use light	SXRM1A2F	
Flush-mounted, IG2000P installed, receptacle NEMA 6-15R, in-use light	SXRM2A2F	
Flush-mounted, IG2000P installed, receptacle NEMA 6-20R, in-use light	SXRM3A2F	
Flush-mounted, IG2000P installed, receptacle NEMA 6-30R, in-use light	SXRM4A2F	
Flush-mounted, IG2000P installed, receptacle NEMA 6-50R, in-use light	SXRM5A2F	
Flush-mounted, IG2000P installed, receptacle NEMA L6-15R, in-use light	SXRM6A2F	
Flush-mounted, IG2000P installed, receptacle NEMA L6-20R, in-use light	SXRM7A2F	
Flush-mounted, IG2000P installed, receptacle NEMA L6-30R, in-use light	SXRM8A2F	
Flush-mounted, IG2000P installed, receptacle Hubbell CS8269 , in-use light	SXRM9A2F	

Overview and Ordering Information

Medical Isolated Power Panels Power and Master Grounding Station Modules

Power Modules

Where room ground extensions and power receptacles are both required, these modules offer convenience and save labor in field wiring. Each unit includes four power receptacles, four twist-to-lock ground jacks, and a ground bus, along with a generous number of lugs for external ground connections.

The main ground connection in the module accommodates up to a 1/0 AWG cable. The unit is completely factory wired—only field power connections and ground connections are necessary. The front trim is #304 stainless steel with a #4 brushed finish.

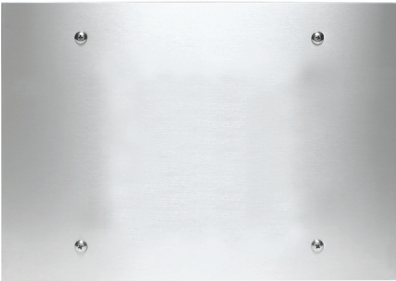
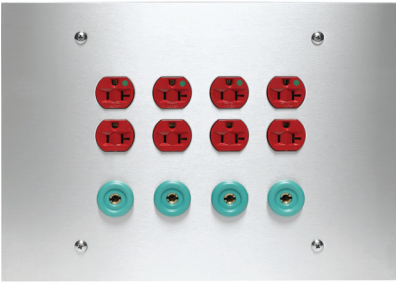

Master Grounding Station Module—120 Series

These modules can be used as a collection point for grounds in a large area, such as a coronary care unit or intensive care ward. The primary application is where the equipment ground bus in the emergency distribution panel is not conveniently located or cannot accept the large number of connections required for the area.

This unit can be connected to the ground point by a single conductor and located in a more convenient area. The module contains a bus bar with 18 lugs for field connections and has a Type #304 brushed stainless steel cover plate. It is designed for installation into a 12 in. x 8 in. x 4 in. back box.

Any combination of eight receptacles or ground connectors is allowed via the Product Selector.

Description	Catalog No.	Back Box Cat. No.
Power module, 4 ground connectors, 4 duplex red, flush-mounted	SGPMF4DR4	SB120804
Power module, 4 ground connectors, 4 duplex ivory, flush-mounted	SGPMF4DI4	
Power module, 2 duplex red, flush-mounted	SGPMF0DR2	
Power module, 2 duplex ivory, flush-mounted	SGPMF0DI2	
Master grounding station, flush-mounted	SGPMF0NN0	
Master grounding station, 4 ground connectors, flush-mounted	SGPMF4NN0	
Power module, 4 ground connectors, 4 single red, trim	SGPMG4SR4	Customer-supplied, four-gang
Power module, 4 ground connectors, 4 single ivory, trim	SGPMG4SI4	
Master grounding station, 4 ground connectors, trim	SGPMG4NN0	
Master grounding station, 2 ground connectors, trim	SGPMG2NN0	

Back Boxes

The back box required is based on the quantity of devices chosen.

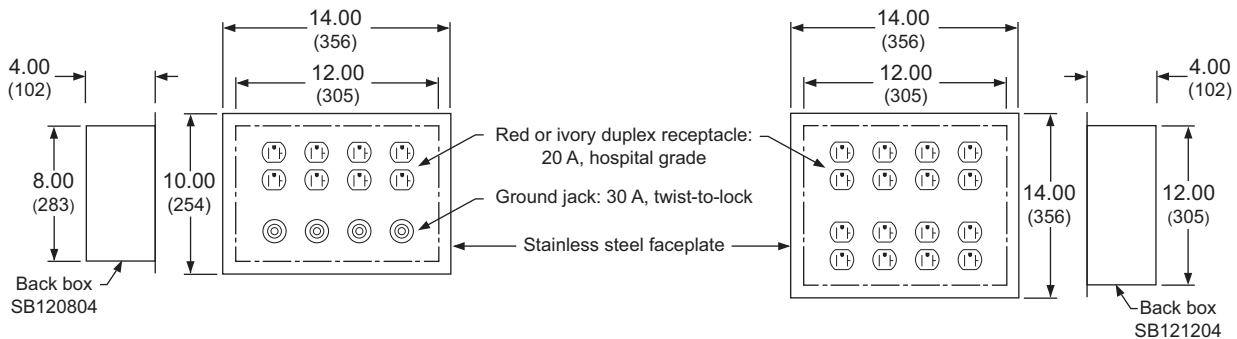

Hospital-Grade Ground Cords



Ground Cord with Lug End



Ground Cord with Clip End



Ground Jack

Description	Catalog No.	Legacy Catalog No.
15 ft., with plug and lug for #10 stud	SHGC15L	P751N
15 ft., with plug and heavy duty clip	SHGC15C	P753N
12 ft., with plug and lug for #10 stud	SHGC12L	Not applicable
12 ft., with plug and heavy duty clip	SHGC12C	
10 ft., with plug and lug for #10 stud	SHGC10L	
10 ft., with plug and heavy duty clip	SHGC10C	
Hospital grade ground jack, 30 A, 250 V, green	SHGJ1R	4319950007

Shorter cables are available. Please contact your local Schneider Electric representative for the correct part number.



IGT Dual Clock/Timer



IGT1550 Remote

Iso-Gard™ IGT Dual Clock/Timer Kit

Features

- Bright-red LED display for enhanced readability under the intense lighting conditions found in hospital operating rooms
- 12/24 hour selectable mode
- Power outage backup for at least 24 hours without batteries
- Designed for flush wall mounting

Ordering Information

Description	Catalog No.
Dual clock/timer with one IGT1550 remote control, stainless steel faceplate, and galvanized steel backbox	IGT

Schneider Electric offers two remote indicators for interfacing with line isolation monitors: the Iso-Gard™ IG2000P and IG2000CBM.

IG2000P Remote Indicator

The Iso-Gard™ IG2000P remote indicator from Schneider Electric provides remote indication of the visible and audible alarms from a line isolation monitor (LIM).



- Green LED—stays illuminated while the system is in normal condition
- Red hazard LED—illuminates when the Total Hazard Current exceeds the preset alarm level
- Audible hazard alarm—sounds when the Total Hazard Current exceeds the preset alarm level
- Mute button with yellow LED—silences the audible alarm on the remote indicator (local muting), or silences all audible alarms in the system (system muting)
- Test button—remotely performs a functional test of the LIM

The IG2000P remote indicator is available mounted in a one- or two-gang stainless steel faceplate for flush mounting into a panel or wall box with a two-inch minimum depth. The basic electrical connection is made using three wires.

Features

- Interfaces with all Iso-Gard LIMs from Schneider Electric (Series 1, A, B, C, D, and 6), as well as with LIMs from other manufacturers
- Does not interfere with medical equipment
- Uses low voltage wiring (12 Vdc or 12 Vac)
- Mounts to a standard, electrical gang box
- Connects by means of a screw terminal strip
- Uses long-life, LED displays
- Features a rugged, easy-to-clean, stainless steel and Lexan design

Mounting	Catalog No.
Customer-supplied single gang box or equivalent	IG2000PG1
Customer-supplied two gang box or equivalent	IG2000PG2
Customer-supplied four gang box or equivalent	IG2000PG4
Designed to mount in legacy Square D™ brand isolated power panel	IG2000PPM
Designed to mount in legacy Square D™ brand backbox (catalog no. 53008BB)	IG2000PST0614

IG2000CBM Remote Indicator

The Iso-Gard™ IG2000CBM remote indicator from Schneider Electric provides remote indication of the visible and audible alarms and digital mA reading from an Iso-Gard Series 6 (IG6) line isolation monitor (LIM).

- Green LED—stays illuminated while the system is in normal condition
- Red hazard LED—illuminates when the Total Hazard Current (THC) exceeds the preset alarm level
- Audible hazard alarm—sounds when the THC exceeds the preset alarm level
- Mute button with yellow LED—silences the audible alarm on the remote indicator (local muting), or silences all audible alarms in the system (system muting)
- Test button—remotely performs a functional test of the LIM
- Digital display—shows the THC in real time

The IG2000CBM remote indicator is available mounted in a two-gang stainless steel faceplate for flush mounting into a wall box with a two-inch minimum depth. The basic electrical connection is made using four wires.

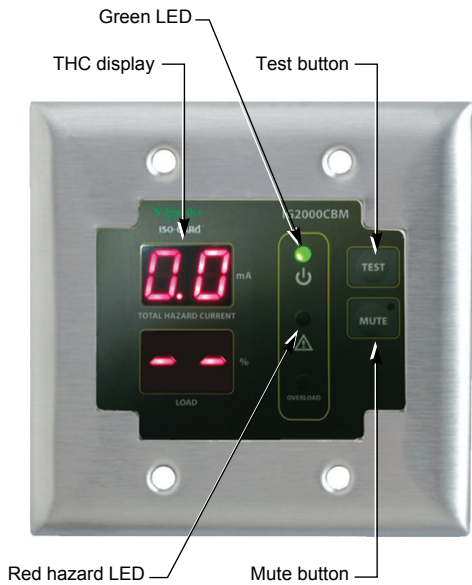

Features

- Interfaces with the Iso-Gard Series 6 LIM from Schneider Electric
- Does not interfere with medical equipment
- Uses low voltage wiring and RS-485 wiring
- Mounts to a standard, electrical two-gang box
- Connects by means of a screw terminal strip
- Uses long-life, LED displays
- Features a rugged, easy-to-clean, stainless steel and Lexan design

Mounting	Catalog No.
Customer-supplied two gang box or equivalent	IG2000CBMG2
Customer-supplied four gang box or equivalent	IG2000PCBM4
Designed to mount in legacy Square D™ brand isolation panel	IG2000CBMPM
Designed to mount in legacy Square D™ brand backbox (catalog no. 53008BB)	IG2000CBMST0614

Outlines

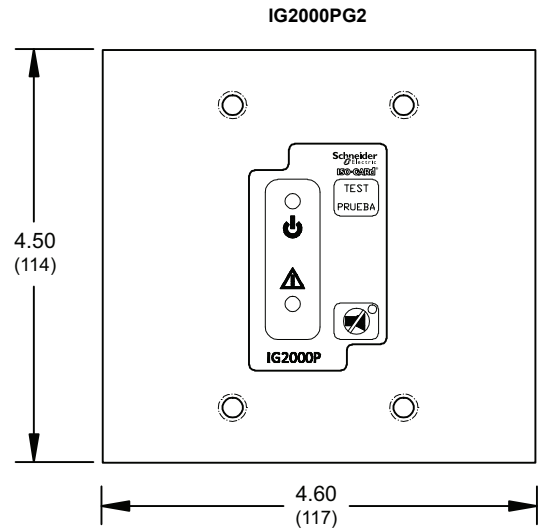
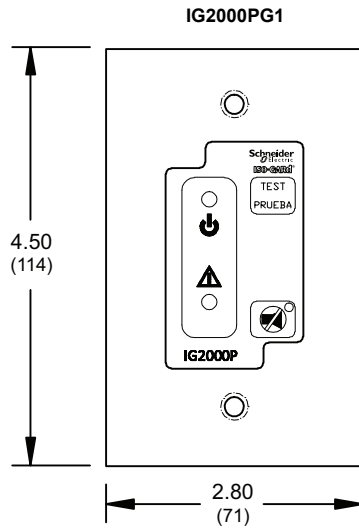

Dual dimensions: Inches
(mm)

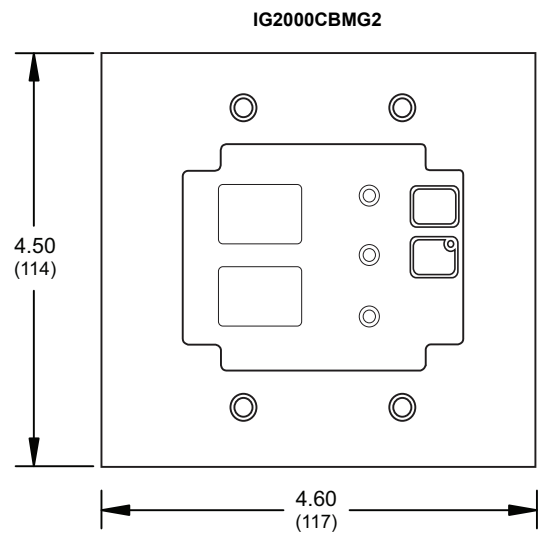

Medical Isolated Power Panels Transformers

The transformer designs in this section are for use only with standard (SIP), duplex (SIX), and dual voltage (SID) isolated power panels manufactured by Schneider Electric.

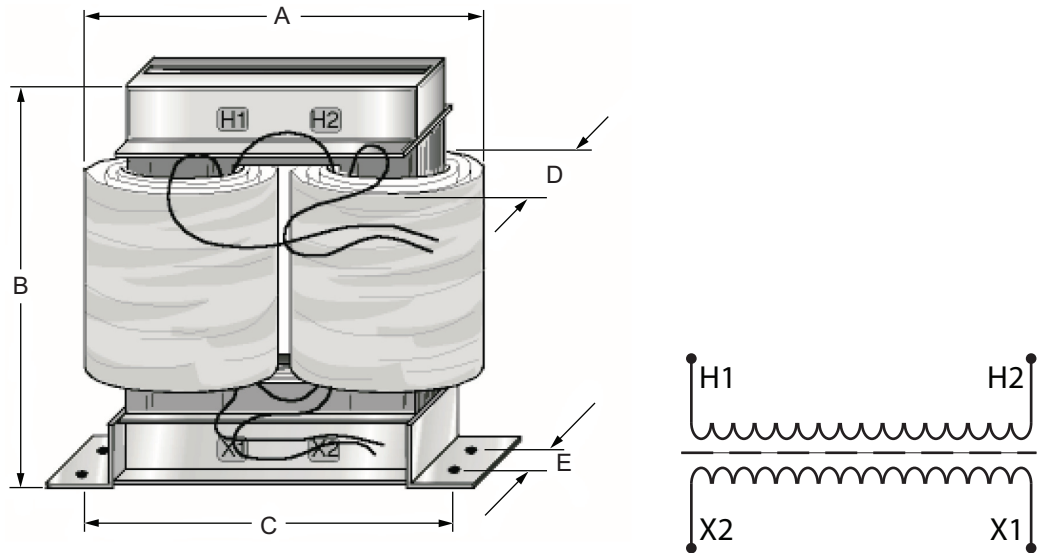

120 V Secondary

kVA	Primary (V)	Catalog No.	Dimensions (inches)					Weight (lbs)
			A	B	C	D	E	
3	120	SXM03AA	14	13.25	14	4	3.25	65
3	208	SXM03BA	14	13.25	14	4	3.25	65
3	240	SXM03CA	14	13.25	14	4	3.25	65
3	277	SXM03DA	14	13.25	14	4	3.25	65
5	120	SXM05AA	16	14.5	14	5	3.25	85
5	208	SXM05BA	16	14.5	14	5	3.25	85
5	240	SXM05CA	16	14.5	14	5	3.25	85
5	277	SXM05DA	16	14.5	14	5	3.25	85
5	480	SXM05EA	16	14.5	14	5	3.25	85
7.5	120	SXM07AA	17	14.75	14	5.5	3.25	110
7.5	208	SXM07BA	17	14.75	14	5.5	3.25	110
7.5	240	SXM07CA	17	14.75	14	5.5	3.25	110
7.5	277	SXM07DA	17	14.75	14	5.5	3.25	110
7.5	480	SXM07EA	17	14.75	14	5.5	3.25	110
10	120	SXM10AA	14	14	14	7	3.25	170
10	208	SXM10BA	14	14	14	7	3.25	170
10	240	SXM10CA	14	14	14	7	3.25	170
10	277	SXM10DA	14	14	14	7	3.25	170
10	480	SXM10EA	14	14	14	7	3.25	170

Medical Isolated Power Panels Transformers

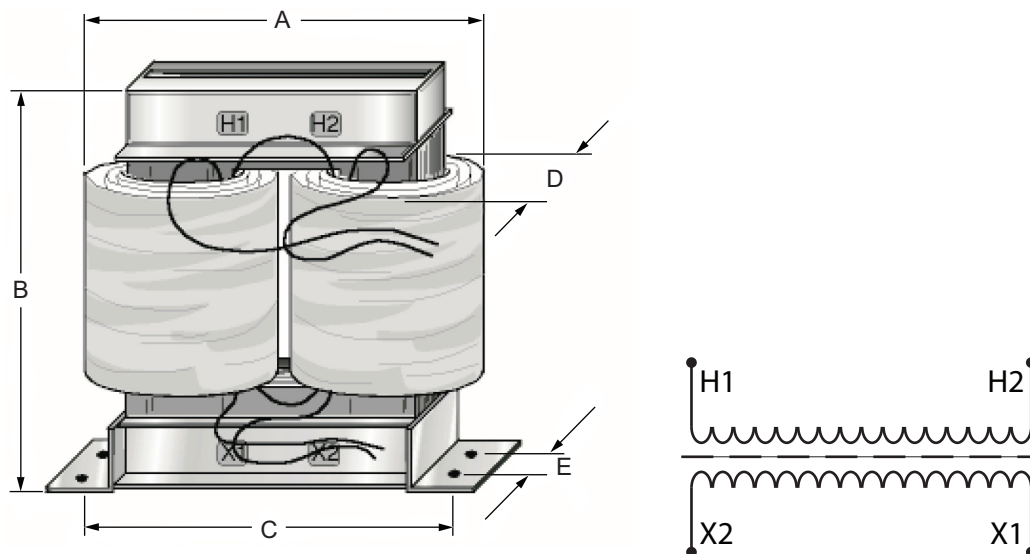

208 V Secondary

kVA	Primary (V)	Catalog No.	Dimensions (inches)					Weight (lbs)
			A	B	C	D	E	
7.5	240	SXM07CB	17	14.75	14	5.5	3.25	110
7.5	277	SXM07DB	17	14.75	14	5.5	3.25	110
7.5	480	SXM07EB	17	14.75	14	5.5	3.25	110
10	240	SXM10CB	14	14	14	7	3.25	170
10	277	SXM10DB	14	14	14	7	3.25	170
10	480	SXM10EB	14	14	14	7	3.25	170
15	240	SXM15CB	15	16	11	8	6.75	170
15	277	SXM15DB	15	16	11	8	6.75	170
15	480	SXM15EB	15	16	11	8	6.75	170
25	240	SXM25CB	17.5	18	11	8.5	6.75	320
25	277	SXM25DB	17.5	18	11	8.5	6.75	320
25	480	SXM25EB	17.5	18	11	8.5	6.75	320

240 V Secondary

kVA	Primary (V)	Catalog No.	Dimensions (inches)					Weight (lbs)
			A	B	C	D	E	
7.5	240	SXM07CC	17	14.75	14	5.5	3.25	110
7.5	277	SXM07DC	17	14.75	14	5.5	3.25	110
7.5	480	SXM07EC	17	14.75	14	5.5	3.25	110
10	240	SXM10CC	14	14	14	7	3.25	170
10	277	SXM10DC	14	14	14	7	3.25	170
10	480	SXM10EC	14	14	14	7	3.25	170
15	240	SXM15CC	15	16	11	8	6.75	170
15	277	SXM15DC	15	16	11	8	6.75	170
15	480	SXM15EC	15	16	11	8	6.75	170
25	240	SXM25CC	17.5	18	11	8.5	6.75	320
25	277	SXM25DC	17.5	18	11	8.5	6.75	320
25	480	SXM25EC	17.5	18	11	8.5	6.75	320

Medical Isolated Power Panels Transformers

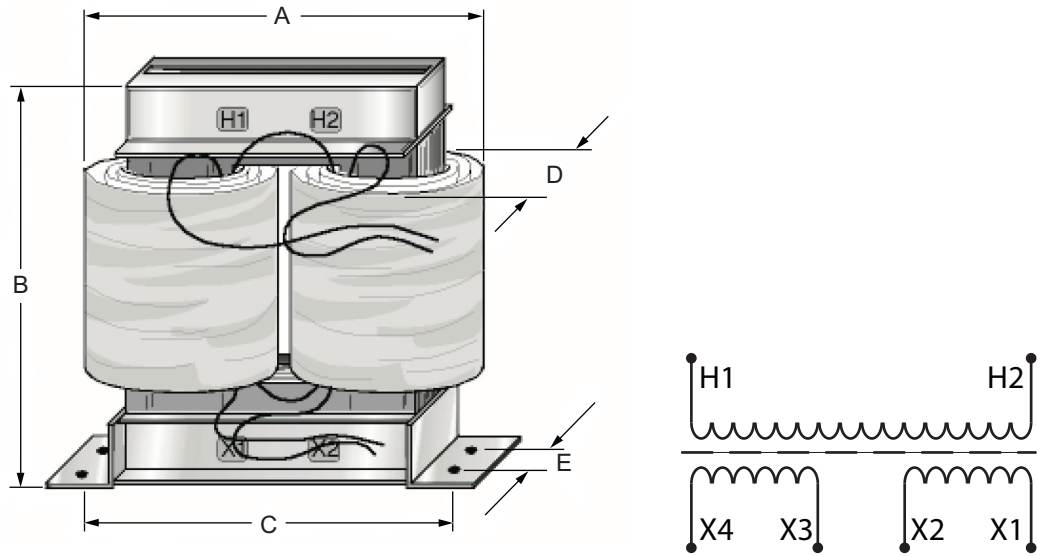

Dual Secondary—120 V and 208 V

kVA	Primary (V)	Dimensions (inches)					Weight (lbs)	Catalog No.
		A	B	C	D	E		
25	240	17.5	18	11	8.5	6.75	370	SXM25CB10
25	277	17.5	18	11	8.5	6.75	370	SXM25DB10
25	480	17.5	18	11	8.5	6.75	370	SXM25EB10

Dual Secondary—120 V and 240 V

kVA	Primary (V)	Dimensions (inches)					Weight (lbs)	Catalog No.
		A	B	C	D	E		
25	240	17.5	18	11	8.5	6.75	370	SXM25CC10
25	277	17.5	18	11	8.5	6.75	370	SXM25DC10
25	480	17.5	18	11	8.5	6.75	370	SXM25EC10

Typical Transformer Performance Data

Rating in kVA	Maximum Leakage Current (µA)		Noise dB	Impedance			Regulations		Efficiency		Losses	
	120 V Secondary	208-240 V Secondary		%X	%R	%Z	80%	100%	50%	100%	0% load	100% load
3	20	30	27	1.50%	2.79%	3.17%	1.82%	2.28%	98.0%	96.3%	45	115
5	20	30	27	2.10%	2.49%	3.26%	1.78%	2.22%	98.6%	97.2%	50	145
7.5	25	37	30	1.84%	1.63%	2.46%	1.28%	1.61%	98.4%	97.2%	92	215
10	25	37	30	1.34%	1.68%	2.15%	2.26%	2.83%	98.6%	97.4%	100	272
15	30	40	35	0.75%	1.35%	1.50%	2.10%	2.30%	98.9%	98.0%	120	290
20	35	50	35	0.55%	0.95%	1.10%	1.20%	1.50%	99.1%	98.5%	120	310
25	35	50	35	0.45%	0.77%	0.89%	0.98%	1.22%	99.3%	98.7%	125	320

Medical Isolated Power Panels Backbox/Front Trim, Replacement Parts

Backbox/Front Trim Combinations

Backbox ▲			Front Trim ■					
			Flush-Mounted			Surface-Mounted		
(H x W x D) (inches)	Weight (lbs)	Catalog No. ◆	(H x W) (inches)	Weight (lbs)	Catalog No. ★	(H x W) (inches)	Weight (lbs)	Catalog No. ★
43 x 24 x 6	49	SB432406	45 x 26	26	ST4526	43 x 24	24	ST4324
43 x 24 x 8	61	SB432408	45 x 26	26	ST4526	43 x 24	24	ST4324
48 x 24 x 8	87	SB482408	50 x 26	28	ST5026R	48 x 24	26	ST4824R
51 x 30 x 12	102	SB513012	53 x 32	37	ST5332	51 x 30	35	ST5130
51 x 30 x 14	120	SB513014	53 x 32	37	ST5332	51 x 30	35	ST5130
51 x 34 x 14	140	SB513414	53 x 36	41	ST5336	51 x 34	39	ST5134
56 x 34 x 14	188	SB563414	58 x 36	45	ST5836R	56 x 34	43	ST5634R
71 x 34 x 8	225	SB713408	73 x 36	57	ST7336▼	71 x 34	55	ST7134▼

- ▲ 14-gauge, galvanized steel construction. Surface-mounted backboxes are painted off white.
- 14-gauge, brushed stainless steel construction.
- ◆ For surface-mounted backboxes, add an "S" to the end of the catalog number.
- ★ For trim with an opening for receptacles and/or ground modules, add an "R" to the end of the catalog number.
- ▼ This is a two-piece trim.

Replacement Parts

These are replacement parts for current line isolation monitors and isolated power panels, not for legacy products.

Description	Catalog Number
Replacement IG6 connector cord	4800IG6C
Replacement IG6 line isolation monitor	IG6M
Replacement panel keys	4800KEY
Transformer mounting hardware and isolation pads	4800S10200000
Trim hardware kit, including keys	4800S10200300

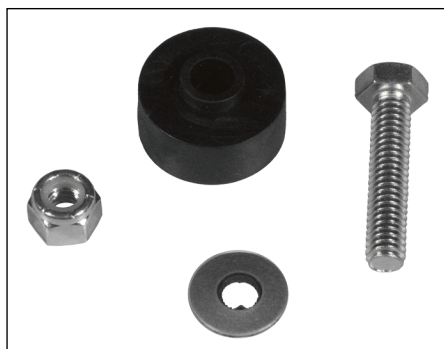

Transformer Mounting Hardware



Trim Hardware Kit

Medical Isolated Power Panels
Miscellaneous Technical Information

UL Listed System, Including Primary Disconnect Device

The primary disconnect device is sized via the UL File and Testing to provide the full capacity of the system. Since the National Electrical Code (NEC) requires the system to be UL Listed, changes cannot be made to the system. The primary device must be sized by the manufacturer and must comply with its third party filing.

Main Disconnect Circuit Breaker Size

kVA	Primary Voltage	Actual Circuit Breaker Rating (A)
3	120	35
	208	20
	220	20
	240	20
	277	15
5	120	60
	208	30
	220	30
	240	30
	277	25
7.5	480	15
	120	80
	208	45
	220	45
	240	40
10	277	35
	480	20
	120	100
	208	60
	220	60
15	240	60
	277	45
	480	30
	120	150
	208	90
20	220	90
	240	80
	277	70
	480	40
	208	125
22.5	220	125
	240	100
	277	90
	480	60
	208	125
25	220	125
	240	100
	277	90
	480	60
	208	150
25	220	150
	240	150
	277	125
	480	70
	208	150

Installing and Connecting Isolated Power Systems

Overall System Recommendation

- Do not place power and control wiring in the same conduit

Conductors

The impedance (capacitive and resistive) to ground of either conductor of an isolated power system must exceed 200,000 ohms when installed. The installation at this point will include receptacles, but is not required to include lighting fixtures or fixture components.

Schneider Electric provides the following additional recommendations:

- Limit 120 V systems to 10 kVA (NEC informational note)
- Minimize the number of circuits (no more than the eight factory-installed branch circuit breakers)
- Minimize the length of conductors
- Do not splice conductors. If you must splice, use compression connectors to minimize the impact.
- Use conductor insulations with a dielectric constant less than 3.5 and an insulation resistance constant greater than 6100 megohm-meters (XHHW or XHHW-2).
- Do not use wire-pulling compound as it may increase the dielectric constant.
- Use conductors with the following colors:
 - Orange with at least one distinctive colored stripe other than white, green, or gray
 - Brown with at least one distinctive colored stripe other than white, green, or grayStripes were added in the 2008 NEC; the previous code requirements were orange and brown.
- Use ¾ in. conduit containing no more than six conductors to minimize leakage.

Control Wire

Use the following wiring/items to connect components of the isolated power system.

Connection between Line Isolation Monitor and Composite Units

- IG2000P—Standard control wiring
- IG2000CBM—RS-485 (shielded twisted pair) and control wiring

Connection between Line Isolation Monitor and Nurse's Station

- Standard control wiring

Medical Isolated Power Panels

Miscellaneous Technical Information

Line Isolation Monitor (LIM)

- Factory settings include a password. For information, please see the *Menu: SETTING / PASSWORD* section in instruction bulletin MED1011010x.
- Error code 8.80 means the clock has reverted to factory settings and needs to be reset. Please see the *Detected Error Codes and Troubleshooting* section in instruction bulletin MED1011010x.
- The LIM alarms when the set leakage current threshold is exceeded. Common causes of this include:
 - Equipment discharging to ground. For example, an internal surge protective device or uninterruptible power supply (UPS). These types of devices should not be connected to an isolated power system.
 - Portable carts containing power strips, UPS systems, GFCIs, etc. Do not use portable carts containing such items with an isolated power system.
 - Input voltage is outside of the device ratings in either amplitude or frequency.

Isolated Power System

- Ungrounded System
 - Since there is no reference to ground, measurements between conductors and ground will vary and do not give relevant information.
 - Two-pole breakers require both conductors to be disconnected together.
 - Surge protective devices are designed for grounded systems and cannot be incorporated in an isolated power system.
 - UPS devices require ground systems and cannot be connected to an isolated power system.
 - An isolated power system is an alternative to a GFCI system for wet locations. GFCI outlets and/or circuit breakers cannot be connected to an isolated power system.
- Transformer Compartment
 - Can be used for wireway to the left and right of the transformer, aligning with the wire access point on the drawing vertically.
- Lighting Circuits
 - Should not be connected to an isolated power system.

Schneider Electric USA, Inc.
800 Federal Street
Andover, MA 01810 USA
888-778-2733
www.schneider-electric.us

Iso-Gard, PowerPact, QO, QOB, Schneider Electric, and Square D are trademarks owned by Schneider Electric Industries SAS or its affiliated companies. All other trademarks are the property of their respective owners.

4800CT1201R09/15 Replaces 4800CT1201R06/15, 06/2015
© 2012–2015 Schneider Electric All Rights Reserved